

# **AIRFIX** magazine

JUNE 1971

**FOR PLASTIC MODELLERS**

**15p**  
MONTHLY

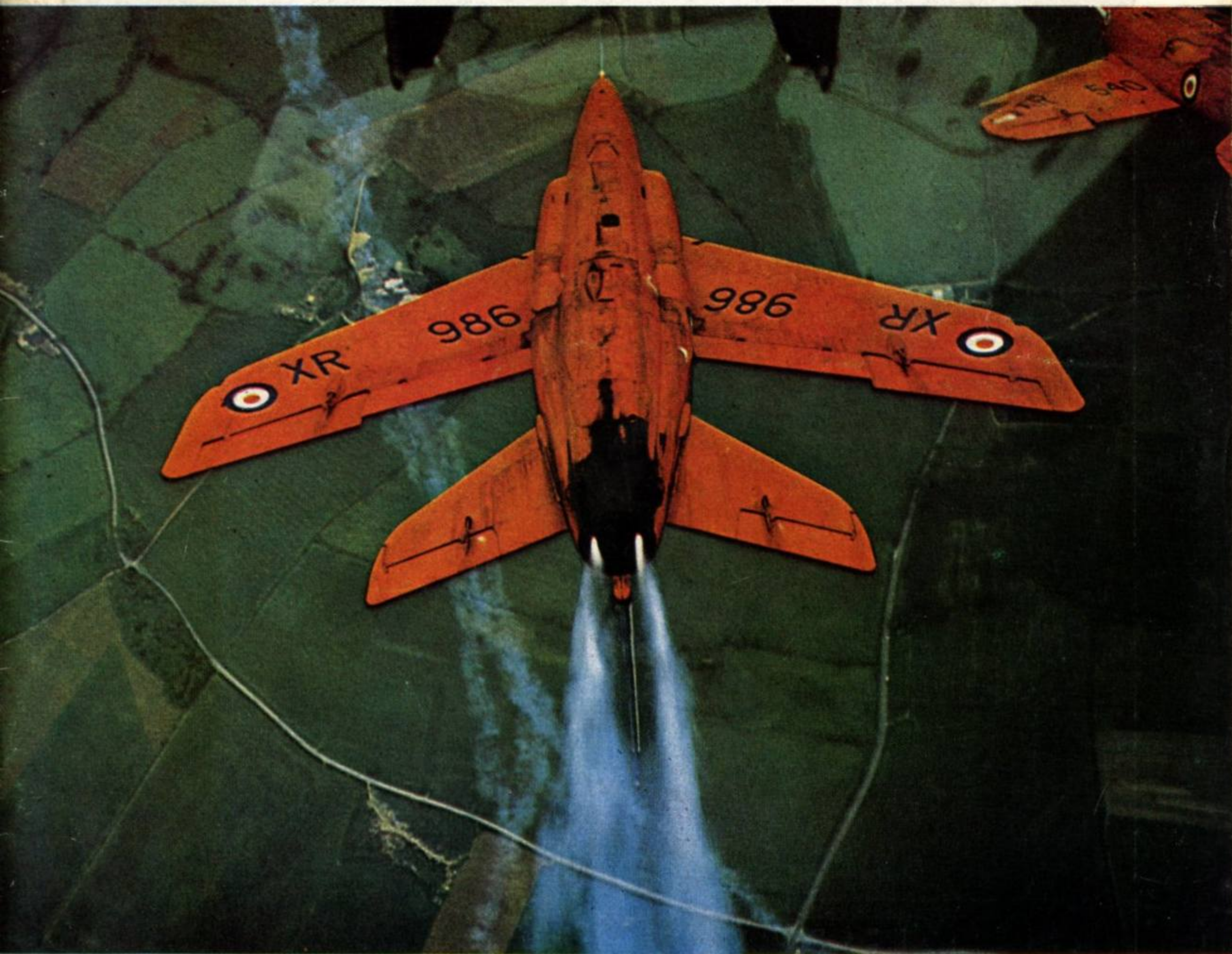

**IN  
THIS  
ISSUE**

Simple Harvard variants and paint schemes  
1914-1918 motor trucks and small station

The three things you need for successful modelling—

**Skill  
patience  
and  
Humbrol**



You've got to work at the first two but you can buy the third at any good modelling shop. Your models deserve the best and you'll certainly get the best from Humbrol. Ask for these products by name—enamels (matt or gloss) for brushing or spraying; modelling adhesives of every kind; craft knives, dopes, thinners, brush cleaners, fuel proofers, authentic colours, metallics and poster colours. **Remember—Humbrol helps you make better models.**

**HUMBROL**

HUMBROL • HULL • YORKSHIRE

**Get every  
detail right  
with Airfix**



It's the little things—like the opening hatches and elevating machine gun on this Centurion tank—that really make the model! And that's why Airfix Construction Kits are so fantastically popular. Every model is accurate to the smallest detail—a perfect replica of the real thing! There are nineteen series each made to a constant scale. Over 300 kits to choose from at prices from 17p. From all good hobby shops and F. W. Woolworth. Ask for the catalogue.

Bottom left: World War I tank Bottom centre: Lee/Grant tank Top left: 88mm Gun Right: Centurion

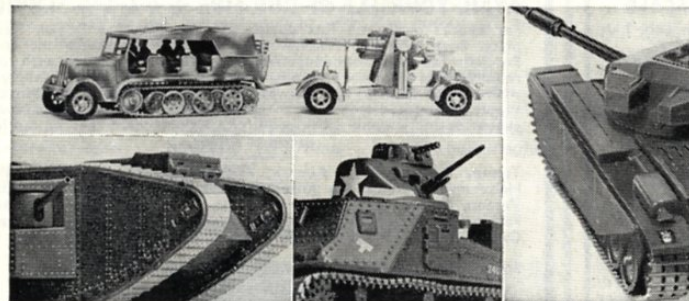

The world's  
biggest range of  
construction kits

**PLANES!**

Over 150 to choose from, including aircraft from both World Wars, modern jets and airliners.



**SHIPS!**

Warships from World Wars I and II, as well as modern liners and historical ships.



**STOP PRESS**

Powered by Rolls Royce RB211 jet engines and designed to operate over short and medium distances, the wide bodied TriStar is capable of carrying up to 345 passengers. This superb Airfix Kit is supplied with Air Canada markings. 85p.



News, articles, conversions for modelling enthusiasts every month in AIRFIX MAGAZINE. 15p from your model shop or newsagent.

# ARGYLE **NEW**

BRITAIN'S LEADING MODEL SPECIALISTS

## FILL THE CONVERSION GAP!

**airmodel**

SOLE U.K. IMPORTERS

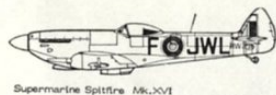

Supermarine Spitfire Mk. XVI



Ju 88 S

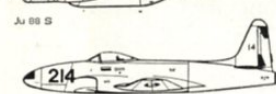

Lockheed F-80 C Shooting Star

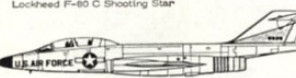

McDonnell F-101 B Voodoo



Hawker Sea Fury T. 20

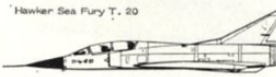

GAM Assault Mirage III B, III BS and III BZ

**ALL AT 15p  
PER SET OF THREE**

Trade enquiries invited

# ARGYLE

## MODELS

CENTRAL STATION BRIDGE, 247 ARGYLE STREET, GLASGOW 2.  
Telephone: 041-248-6686 and at 103 HIGH STREET, THE ROYAL  
MILE, EDINBURGH. Telephone: 031-556-4402.

## Set the scene with Plasticine

You can landscape your setting and populate your model world with figures in 'Plasticine'. Whether you're building up a contoured hillside or modelling drivers and mechanics for your racing circuit, there's a world of scope in a pack of 'Plasticine'. Economy packs contain 1 lb., with a choice of 18 different colours. From all good toy and stationery shops and suppliers of artists' materials.



**A Harbutt PRODUCTION**

Sole Manufacturers:  
**HARBUTT'S PLASTICINE LTD., BATHAMPTON, BATH, BA2 6TA**

IF IT'S SERVICE YOU REQUIRE  
REMEMBER THE NAME



## HOWELL DIMMOCK LTD

THE SPECIALISTS IN WORLD-WIDE MAIL ORDER

AVAIL YOURSELF OF OUR FIVE ★★★★★ SERVICE

For export customers just deduct 2/11ths from the British Retail price. Bear in mind electrical equipment and books do not carry Purchase Tax so do not deduct from these items. Write to us with your requirements and we will airmail proforma or invoice by return. If you wish you can establish a sterling balance with us to further speed up the supply of goods. Remember all goods are supplied with our refund guarantee and we only stock goods of a high standard that we can feel proud to supply.

Triang, Trix, Minitrix, Almark, Airfix, Frog, Superquick, Profiles, Fleischmann, Mopok, Ian Allan, David & Charles, Peco, Dola, Kibri, Wrenn, Minitanks, Humbrol, Mod-Roc, P.S.M., P.C., B.S.L., Graham Farish, Hammant & Morgan, Codar, Scalespeed, Wills, K's, Gem, and Oxford Publishing Co. are just a few of the many manufacturers we stock.

For the model railway enthusiast we have our exclusive  
**PAINTING AND LINING SERVICE**

Our painter is not only a craftsman but one of the best in the country. Why not send a S.A.E. for details and estimate for painting your favourite locomotive.

U.K. Mail Order: Orders over £5 free; Up to £2, 12½p; Over £2 but under £3, 15p; Over £3 but under £5, 20p. Power units and transformers 30p. Flexible track extra 12½p.

## HOWELL DIMMOCK LTD.

Call, write or phone 01-808-5675  
38-40 Lordship Lane, TOTTENHAM N 17 8NT ENGLAND  
Hours of Business 9am-6pm closed all day Thursday

## New books and kits for enthusiasts—from Almarks

JUST PUBLISHED—TWO ESSENTIAL GUIDES  
FOR UNIFORM ENTHUSIASTS

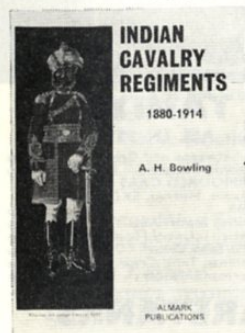

**INDIAN CAVALRY  
REGIMENTS, 1880-1914**

By A. H. Bowling

A magnificently illustrated volume in the style of the author's previous books. It covers all the Indian cavalry regiments in order with historical details and uniform notes. 115 uniforms are shown in colour, and there are fine line drawings showing all uniform styles and detail items. There are also many contemporary photographs, completing a splendid history of a fine military force.

Paperback £1.25;

Hardback £1.75.

We have an 8 page descriptive catalogue available (free on receipt of a S.A.E.) describing all Almark books.

Hardback editions of our most recent titles are casebound and with separate dustjackets.

**REGIMENTS AT  
WATERLOO**

By Rene North  
A superb reference book for the uniform, model soldier and wargame enthusiast. Written by a noted authority on the period, it provides in a single handy volume, packed with colour illustrations, a complete guide to the Anglo-Allied and French sides in the great battle of June 18, 1815. Book includes all these fine features: 15,000 words of text; over 60 figures shown in colour; 67 (approx.) uniform drawings; complete order of battle; glossary of terms; half-tone prints; 72 pages; 8 pages in full colour.

Paperback £1.25;

Hardback £1.75.



## Kookaburra Books FOR ALL AIRCRAFT ENTHUSIASTS

We are exclusive UK and European distributors for these world-famous aircraft books. All are packed with fine colour art, rare pictures, data, scale drawings and authoritative text.

**Available now:**  
*Wirraway and Boomerang Markings* (G. Pentland).  
*Hawker Hurricane Described* (F. K. Mason).  
*Combat Aircraft of the Battle of Britain* (A. Shennan).  
*Spitfire Markings of the RAAF Pt. 1* (T. Bennet).

**Available soon:**  
*Focke Wulf Fw 190 Pt. 1 and Pt. 2* (Pentland/Shennan) (2 books).  
*Markings of the Aces 8th USAF* (T. Bennet).

UK price  
50p each

*P-47 Thunderbolt Described, Pt 1 and Pt 2* (G Duval). (2 books).  
*Westland Whirlwind Described* (B. Robertson).

For a free leaflet on the Kookaburra range of books, send a SAE to the address below right

Below: Five new or recent titles.



RECENTLY PUBLISHED

**SHIPS OF THE  
ROYAL NAVY**  
By W. D. G. Blundell

An up-to-date and profusely illustrated reference book covering ships currently in service. 120 illustrations in all. Every class of ship is shown by a 1:1200 scale drawing as well as pictures, data and historical notes. 72 pages.

Paperback £1.25; Hardback £1.75 (each).

**'BATTLE' CLASS  
DESTROYERS**  
By Peter Hodges

This is a monograph devoted to the famous Royal Navy 'Battle' Class ships. Every ship is illustrated; there is a detailed historical and technical coverage including cut-aways of weapons systems. Every ship's badge is shown in colour. 64 pages.

READY SOON

**BRITISH MILITARY  
MARKINGS, 1939-1945**

By Peter Hodges

An indispensable reference book for all AFV modellers and enthusiasts, this fine new book provides a highly detailed guide to formation signs, unit serials, tactical signs, etc. All you need to know. 64 pages, 7 colour plates, scores of pictures.

Paperback £1.25;  
Hardback £1.75.

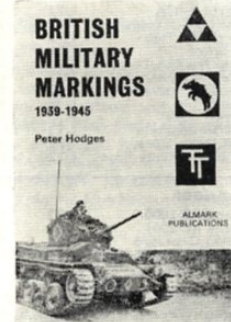

Other Almark Books available:

Japanese Army Uniforms and Equipment, 1939-1945; German Artillery, 1914-18; British Infantry Regiments, 1660-1914; German Combat Uniforms, 1939-1945 (2nd Ed); American Civil War Infantry. All at 87½p (paperback) or £1.25 (hardback).  
F-4 Phantom II; M4 Sherman Production Models; American Armoured Cars, 1939-45; All at 62½p (paper covers only)  
Wehrmacht Divisional Signs. £1.25 (paperback) or £1.65 (hardback). British Infantry Colours £1.00 (paperback) or £1.50 (hardback)  
French Napoleonic Artillery. Soviet Combat Tanks, 1939-45. £1 (paperback) or £1.40 (hardback) each.  
Afrika Korps; Panzerjager ('Wehrmacht Illustrated'). Each at 50p (paper covers only).

## ALMARK KITS

AVAILABLE NOW

**Designed by Charles Stadden**  
Top quality 54 mm (1:32) scale figure assembly kits. Easy to make-up. Hard polystyrene.  
F1. German Panzer-Grenadiers  
F2. Japanese Infantry 1939-45.  
75p each kit

NEW RELEASE

F3. AMERICAN INFANTRY/  
PARATROOPS 1943-45.  
13 figures, including seated driver or passenger. Detailed painting instructions included.

More releases in this series soon—see future advertisement.

Our set of American troops can be painted up for Europe in the M1943 Combat Dress, or for the East in the M1945 Jungle Dress. With a minor change in pockets they can also become paratroops. They thus make suitable opponents for our earlier German and Japanese troops. There are tremendous conversion possibilities. Separate helmets or field caps. Set includes a bazooka and BAR. Figures are in assorted action positions.

**ALMARK  
PUBLISHING CO. LTD.**  
104/106 Watling Avenue  
Edgware, Middlesex



## NEW HASEGAWA SHINMEIWA PS-1

JAPANESE MARITIME  
S.T.O.L. AMPHIBIAN 1/72  
£3.75

PLUS IN STOCK

Lockheed T-33A	1/72	34p
Curtiss SOC-3 Seagull	1/72	34p
T-38A (F-5B) Talon	1/72	34p
F-86F Sabre	1/72	34p
Heinkel HE.51A-1	1/72	34p
Heinkel HE.51B-2	1/72	63p
C. Seagull Floatplane	1/72	63p
Cessna A-37A	1/72	63p
Type 94-1 "Aiji"	1/72	75p
Mitsubishi "Betty"	1/72	£1.44
F-106A Delta Dart	1/72	90p
H6K5 Mavis Flying Boat	1/72	£3.14

ITALAEREI

Reggiane RE-2000	1/72	59p
Reggiane RE-2001	1/72	59p
Fiat G-55 Centauro	1/72	59p
Fiat BR.20 Cicogna	1/72	£1.85

RAREPLANES/RAREJETS

Grunman F.3F	1/72	60p
Bell Aircomet	1/72	65p

Plus other kits in this EXPERTS range

CATALOGUES

AIRFIX 1971 (Colour) 15p plus 5p post.
REVELL 1971 (Colour) 10p plus 5p post.
FROG 1969 (Colour) 10p plus 5p post.

### HOW TO ORDER

UK and OVERSEAS  
Send payment in full. We accept Cash, P.O.'s, Cheques, Money Orders. (outside U.K. add 10% post.)  
Up to 50p, 5p. 50p to £1, 8p. £1 to £5, 30p. £5 and over, FREE

## Douglas Miniatures (MAIN AGENTS)

**NEW 1971 CATALOGUE**

7p + 3p post

54 mm Range of these Low Priced superb figures.  
20 mm Wargamer fine cast detailed miniatures. Napoleonic, Crimean, Seven Years War.  
PLUS 30 mm Skybird range  
PLUS Painting instructions  
Line Drawings, Pictures



A WELL ESTABLISHED MONTHLY SERIES  
DEALING WITH AIRCRAFT, A.F.V., LOGOS.

Your troubles are over. We can supply all Profiles (subject to availability). Send a stamped addressed envelope (U.K.). Overseas customers a postal coupon, we will despatch to you the latest lists dealing with all Profiles (Aircraft, AFV, Loco, Warships). Our appointment as East Midland Trade Distributors enables all traders in 10 counties to purchase from one source. Send for details on your letter head.

## By TAMIYA

NEW!!! ALL IN STOCK

1/35 Kubelwagen and Crew	65p
1/35 Schwimmwagen	65p
1/35 ARMoured CARS	
Saladin, Hornet, SKDfz.222	
E.B.R.	75p
1/35 British 6 pdr. Anti-Tank Gun	65p
1/35 British Infantry (Tommys)	24p
1/35 U.S. Tank Crew	24p
1/35 German Tank Crew	24p
1/35 German Infantry	24p

## RARETANKS

NEW

SOMUA S/35	1/76	45p
French Battle Tank		
GERMAN A.F.V.	1/76	45p
W.V.I German Tank		

Vac formed. All parts included

## 'ENTHUSIASTS CORNER'

Scratch Build or Convert  
READ 'How To Go Plastic Modelling'  
£1.50 plus 10p post.  
'Advanced Plastic Modelling'  
£2.00 plus 10p post.

MATERIALS

.010 Clear Plastikard	9p
.020 Clear Plastikard	12p
.010 White Plastikard	6p
.020 White Plastikard	8p
.030 White/Black	12p
.040 White	17p
.060 White	27p

Mek Pak Liquid Cemen: 12p and 25p.  
Plastic Rod XD 25p. Asst. Micro Strip 25p. Body Putty 15p. Metal Skin (Gloss or Matt) (2 sheets) 25p.

SPECIAL  
.005 White Plastikard 7p  
You can virtually 'dress' 54 mm model soldiers with this extra fine material.



# ERNEST BERWICK

## THE MODEL SPECIALISTS

11A NEWLAND STREET, KETTERING, NORTHANTS., ENGLAND. Telephone KETTERING 5998

A.G. CLARKSON R.C. SEDDON M. CLARKSON

# aviation books galore!

History - Reference  
Modelling - Engineering  
Computers - Navigation  
Flying - Construction

We carry a comprehensive U.K. and International range of books on all aspects of aviation and armour.

Send 12p for list. Refunded on orders of £2.50 or more. Personal callers welcome.

Motor Books & Accessories 33 (AM) St. Martin's Ct., London WC2

Tel: 01-836 5376

## Edward Surén "Willie"

Member of the Guild of Model Soldier Manufacturers  
High Quality 30 mm Military Figures.

Unique Figures made to order. New Price List 20p

Also  
Books, Prints and Original Paintings and Drawings.  
Ceramic Sculptures, Large Display Figures, etc.,  
Available and on Special Order.

HINCHLIFFE 30 mm ARTILLERY ALSO STOCKED.  
Weekdays, 09.00-18.00. Saturdays, 10.00-13.00.

60 Lower Sloane Street  
London S.W.1

Tel. 730-7615.

## "SHIPS"

1/1200 Scale: Metal Die-Cast; Waterline Models  
Tri-ang Minic Ships

One of the finest detailed ranges of model ships ever manufactured. At never to be repeated prices.

Cruisers; H.M.S. Swiftsure and Superb 17½p each (3/6)  
"County" Class Guided Missile Destroyers 12½p each (2/6)  
"Daring" Class Destroyers 12½p each (2/6)  
"Battle" Class Destroyers 12½p each (2/6)  
Frigates 12½p each (2/6)  
"Ton" Class Mine Sweepers 7½p each (1/6)  
S.S. Isle of Guernsey and S.S. Sark 17½p each (3/6)  
M.S. Port Aukland 32½p each (6/6)  
T.S.S. Vikingen (Whale Factory Ship) 32½p each (6/6)

Postage and Packing 2½p (6d) per item;  
Over £5 post free  
List of M.N. Ships, Tugs, Breakwaters, Piers, etc. available

## MODEL FIGURES & HOBBIES

8 College Square North, Belfast BT1-6AS  
M.F.H. POST FREE PUBLICATIONS  
Sea Battle Games by P. Dunn £1.25 (25/-)  
A Reference of German Decorations 50p (10/-)  
Soldiers of the 3rd Reich photo book 50p (10/-)

## MODEL CORNER

30 NORTH STREET, HORSHAM, SUSSEX  
Telephone Horsham 61533  
TANKS BY MAIL

TAMIYA 1/25 Scale		NICHIMO 1/35 Scale	
CHIEFTAIN	£4.99	CENTURION	£2.25
JAGD PANTHER	£4.99	CENTURION	£2.00
75mm. ASSAULT GUN	£3.75	1/30 Scale	
1/35 Scale		PZK IV	£3.75
HUNTING TIGER	£2.99	PANTHER PZK V	£3.75
LEOPARD	£2.99	PZK VI TIGER I	£3.75

Many other Tanks and AFVs from 99p  
SCENIC MATERIALS OUR SPECIALITY  
Post and Packing 5p (1/-) in £ U.K. only  
EXPORT ENQUIRIES INVITED—Horsham 61533

## BOOK BARGAINS FOR ENTHUSIASTS

The military titles in the 'Discovering' series cost only 22½p and 25p. They are concise, authoritative and well illustrated.  
Discovering Antique Firearms 25p.  
Discovering Battlefields in Northern England and Scotland 22½p.  
Discovering Battlefields in Southern England 25p.  
Discovering English County Regiments 25p.  
Discovering Militaria 25p.  
Discovering Military Traditions 25p.  
Discovering Model Soldiers 25p.  
Discovering Wargames 25p.  
From your stockist or by return (adding 3p postage) from  
SHIRE PUBLICATIONS (AC), TRING, HERTS

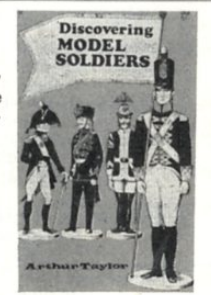

## The First Paperback Editions of the World Famous British Battles Series

These authoritative, finely illustrated books which make excellent use of eye-witness material are an asset to students, teachers, collectors of militaria, model makers and wargamers alike. In series form they provide a companion to the history of the British Army and Royal Navy. By highlighting certain campaigns, explaining the background to particular battles, evaluating weapons and tactics, they pay tribute to the unsurpassed reputation of the British fighting man from Agincourt to Matapan.

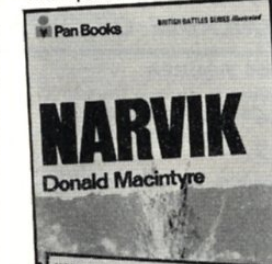

**NARVIK**  
Donald Macintyre  
The desperate struggle for Norway in the spring of 1940 ranks with the timeless gallantry of Arnhem and Dunkirk. It was here that the dash and daring of the Royal Navy - signaled by the award of three VCs - took heavy toll of the German Navy, which was left incapable of protecting Hitler's planned invasion of England. 30p



**BATTLES OF THE BOER WAR**  
W. Baring Pemberton  
40,000 Boer farmers declare war on the British Empire, defeat the most experienced regular army of the day, and make it a capital offence to shoot a British General. It was the last of the Gentlemen's Wars and the first of the modern wars. But for the blood-stained lessons learned on the veld, 1914 might well have ended in defeat. 30p

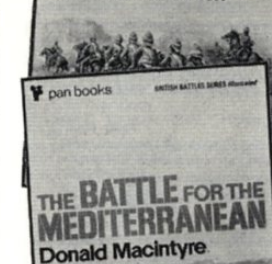

**THE BATTLE FOR THE MEDITERRANEAN**  
Donald Macintyre  
From May 1940 to June 1943, the Navy battled to control the Mediterranean and deny Rommel his lifeline. Captain Macintyre's book pulses with the tense excitement of great convoys, Taranto, Matapan, the fleet's ordeal off Greece and Crete, and sorties by small ships, planes, and submarines from defiant Malta, as the heroism of our seamen decides the fate of North Africa. 30p

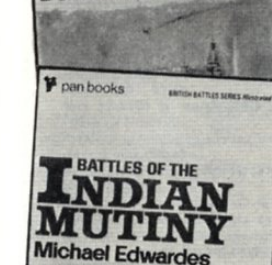

**BATTLES OF THE INDIAN MUTINY**  
Michael Edwardes  
Meerut, May 10th, 1857. Mutiny - and it seemed as though the British must be swept away by 'the Devil's Wind' which raged through Northern India. But, in a war renowned for its atrocities, incompetence, bizarre events and personalities, British soldiers, still clad in scarlet and gold beneath blazing skies, fought and won a succession of bloody battles. The East India Company was dead. Long live the Raj. 35p



Pan Books are available from all good bookshops





## TOP FLIGHT MODELLERS . . . USE TOP FLIGHT FINISHES

### 'JOY' LUMINOUS PAINT : 'JOY' New Formula PLASTIC ENAMEL

(Green shade only).

See in the dark outfits, containing Base Reflecting Coat and Luminous Top Coat.



The 18 beautiful contemporary colours, including black and white, can be intermixed to provide a wide range of colours, Joy Plastic Enamel has good flow, and is resistant to heat and most fuels. It gives glass-hard abrasion and wear resisting surface.

All colours are lead free and are safe to use on children's toys, etc.



### 'JOY-PLANE' BALSA CEMENT



New and improved quality. Very quick and hard setting. Penetrates deeply and is heat resisting and fuel proof.



### 'JOY-PLANE' POLYSTYRENE CEMENT



Non-stringing, quick-drying and odourless. The perfect adhesive for giving a weld joint to any polystyrene surface.

### OTHER PRODUCTS MADE BY MODELLERS FOR MODELLERS

'JOY-PLANE' CELLULOSE DOPES.  
'JOY-PLANE' CLEAR DOPES.  
PLASTIC WOOD.  
BANANA OIL. No. 1. Thick. No. 2. Thin.  
TISSUE PASTE. Tubes.

**JOY** is the registered trade mark of

**TURNBRIDGES LIMITED, LONDON, S.W.17**

manufacturers of quality products for  
STICKING, STAINING, POLISHING, PAINTING

AIRFIX magazine

# AIRFIX magazine

FOR PLASTIC MODELLERS

June 1971

Editorial Offices:  
PSL Publications Ltd  
9 Ely Place  
London, EC1N 6SQ  
Tel: 01-405 2297

Editor: Chris Ellis

Assistant Editor: Peter Woodhouse

Volume 12 No 10

#### Cover Picture

Highlight of many an air show for several years past, and promising to perform better than ever in 1971, the Red Arrows, official RAF aerobatic team, carry out their polished manoeuvres with a precision that looks deceptively easy to spectators on the ground. Such accurate flying, like all good performances, demands plenty of concentrated practice and it was on a training mission last summer that artist Michael Turner took this spectacular view of Gnat XR986 as the formation of aircraft went 'over the top' of a loop. Michael Turner was in the cockpit of the following aircraft and XR986 really was that close in front - no need for a telephoto lens! Our picture shows the whole area of Turner's original transparency, with the Gloucestershire countryside coming up fast below. Michael Turner made this flight to get ideas for an official Red Arrows painting he subsequently completed. The original painting is now with the Red Arrows but full colour prints of it are available from Studio 88, 95 West End Lane, Pinner, Middx, price £1.50 each.

Next publication date:  
June 25, 1971

Advertisement Representatives:  
Jackson-Rudd & Associates Ltd  
84-86 Gray's Inn Road  
Martin House  
London, WC1

Advertisement Manager: Jim Boyd  
Tel: 01-405 3611  
June, 1971

#### Contents

In the Air: latest aviation news from Alan W. Hall	510
'River' Class Frigates: first of two articles by Peter Hodges	512
Siege Artillery: weapons for medieval wargames by Terence Wise	516
Narrow Gauge Station: simple railway model by Michael Andress	518
Model Soldiers: conversions with new materials by Roy Dilley	520
Transport of 1914-1918: three military trucks by Gerald Scarborough	522
Simple Harvard Variants: ideal conversions for beginners by Alan W. Hall	525
Book Reviews: new publications of interest to modellers	533
American Half-Tracks: first of a new series by Peter Chamberlain	534
Air Shows 1971: listing for aviation enthusiasts	535
Bombing Colours: the early Halifax by Michael J. F. Bowyer	536
1815: modelling Prussian troops by Robert C. Gibson	541
New Kits and Models: latest releases reviewed for modellers	543
Photopage: RN and RAF aircraft pictures from readers	546
Letters to the Editor: your chance to win a free Airfix kit	547
New Airfix Kits: two new releases described	548

#### Circulation Department:

SurrIDGE Dawson & Company (Productions) Ltd  
Publishing Department, 136/142 New Kent Road, London, SE1  
Telephone: 01-703 5480

Airfix Magazine is published for the proprietors, Airfix Products Ltd, by PSL Publications Limited, on the fourth Friday of each month. Annual subscription rate £2.40 (USA \$6.50) from SurrIDGE Dawson & Company (Productions) Ltd. Second Class postage paid at New York Post Office, N.Y.

© All articles and illustrations published in AIRFIX MAGAZINE are strictly copyright, and may not be reproduced without written permission from the Publishers. The Editor welcomes the submission of editorial material, which should be accompanied by return postage. Though every care is taken, the publishers cannot accept responsibility for safe keeping of editorial contributions.



MEMBER OF THE AUDIT  
BUREAU OF CIRCULATIONS



First for export. One of the Indian Navy Sea Kings seen recently at Yeovil. Colours are white top decking and mid-blue fuselage. Codes and serials are in white.



WESTLAND Helicopters expect to share in the production of close on 1,000 military helicopters under the Anglo-French co-operative programme covering the Puma, Gazelle and Lynx aircraft. Orders could extend production to 1,500 machines and eventually over 2,000 helicopters may be bought as a result of the 'package deal' linking Westland and Aerospatiale signed in February 1967. With a work force of 15,000 the two companies are now one of the world's largest helicopter groups.

These forecasts were made early in April by Dr G. S. Hislop, Managing Director of Westland Helicopters, at a Press conference to show the Lynx to journalists. Dr Hislop said, 'We are already planning on firm requirements for over 350 Lynx and additional sales could more than double this figure.'

Orders expected for the Lynx, which is a high performance helicopter in which Britain has design and sales leadership, include 150 for the British Army, 80 for the French Navy and 100 for the Royal Navy. It is also a contender for the US Navy's LAMPS anti-submarine aircraft programme, which will call for over 200 shipborne helicopters.

The first of 12 prototype Lynx aircraft made a successful flight at Westland's Yeovil works on Sunday, March 21. The pilot for the 15 minute flight was Mr Ron Gellatley, chief test pilot of Westland Helicopters. The event took place at 6 pm in very poor weather and was followed shortly after by a second 20 minute flight.

Trident 3B, G-AWZC, gets airborne from Birmingham's Elmdon airport during the recent evaluation and crew training programme conducted there. Aircraft of this type which feature a fourth boost engine at the base of the fin and rudder, entered service with BEA last month (S. G. Richards).



The Lynx is a general purpose helicopter and is the most advanced and last to fly of the three helicopters in the 'package deal'. It is powered by two 900 shp Rolls-Royce BS360 free turbine engines, and has a hingeless or semi-rigid rotor driven through conformal gearing. This hingeless rotor head has reduced working parts and the articulations of current helicopters to a minimum. It has only four lubrication points when some of today's helicopters have over 50. The gearbox employed with this rotor has a new form of gearing in which the gears are twice as strong and much simpler than those currently in use. Also the rotor blades have certain innovations which followed research by the National Physical Laboratory, Teddington, and include steel and fibreglass in the manufacture so that a high corrosion resistance is imparted.

Deliveries of the Lynx are due to begin in the autumn of 1973 to the British Army and in 1974 to the Royal and French Navies. A civil version should also be flying by 1974. Production on the aircraft will be split broadly 65/35 per cent between Britain and France. All 12 prototypes will be assembled at Yeovil using both British and French components. The production line is also being established at Yeovil. Two prototypes will be transferred to France for the French trials programme and a third will be used by Rolls-Royce for engine development.

Overseas orders for the Lynx could be considerable and already

Two views of a Sea Fury recently restored to flying condition by Canadian Forces pilot Ormond A. Haydon-Baillie at Vancouver International airport. The aircraft now serialised WH589 has the codes HB-O. It was discovered at Bankstown, Australia, where it had been retired from the Royal Australian Navy in 1962. This nicely applied camouflage finish is, of course, spurious for a Sea Fury (Ian Macdonald).

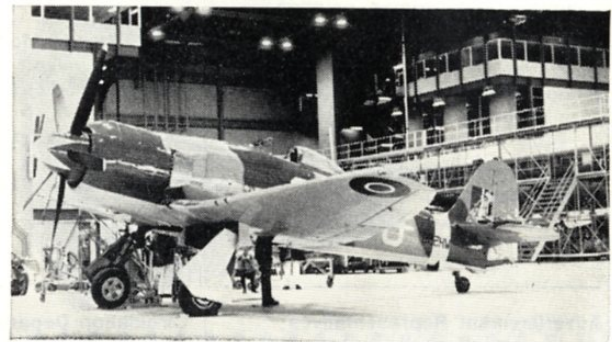
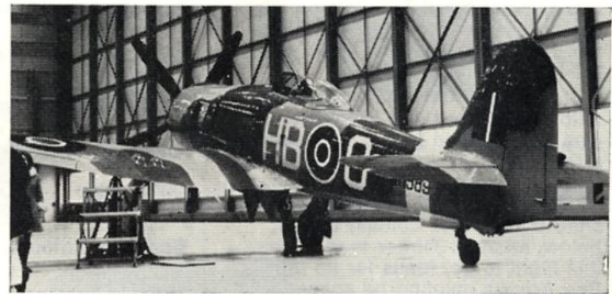

the Argentinian Navy has ordered two, as part of a shipborne weapon system. The cost of the Lynx is believed to be around £220,000 for the British Army aircraft which has a relatively simple navigation/communication system but may be about £275,000 for the Navy version, which is equipped for anti-submarine work.

The first prototype which was flown from Yeovil and shown to the Press was painted yellow overall and had the serial XW835. It has been built in the Army configuration.

### Trident 3 exceeds performance guarantees

BRITAIN'S newest civil airliner to enter service, the Hawker-Siddeley Trident 3B, has exceeded its performance guarantees by a handsome margin, confirming it as one of the cheapest-to-operate aircraft of its kind in the world.

The performance boost, which has dramatically raised export prospects for this Rolls-Royce powered aircraft, has been confirmed through flight tests which revealed that drag is lower than expected and in consequence the fuel consumption in cruise is three to four per cent less than originally estimated.

Efficient design of weight control has brought a reduction of three-and-a-half per cent in the aircraft's equipped weight compared with the original estimate. With take-off performance aided by the Rolls-Royce RB162 boost engine, the aircraft now has an increased payload carrying capability on all routes.

Where there is no airfield performance limitation the payload is increased by at least 3,000 lb up to 31,000 lb. From airfields with limitations, payload guarantees have been exceeded by between 4,000 lb and 9,000 lb. Operationally this means that in certain circumstances the Trident 3 can operate with up to 15 more passengers and their luggage than was originally expected.

So far four Trident 3Bs have flown, the first being on December 11, registered G-AWYZ. Since then, G-AWZA flew on March 9, 1970, G-AWZB on August 18, 1970, and G-AWZC on December 24, 1970.

Much of the evaluation work from which Hawker-Siddeley's have been able to ascertain the performance characteristics of the Trident 3B has taken place at Birmingham's Elmdon airport. Spotters in the Midlands have been delighted to see 'their' airport used for part of the flight trials of the aircraft. Apart from Elmdon, research airfields such as that at RAE Bedford and the manufacturer's airfield at Hatfield have been used.

Apart from evaluation work, the new Trident's frequent visits and overnight stops at Birmingham have been for crew training



Above and right: Dan-Air have, since the beginning of March, been operating charter services from Birmingham (Elmdon), Comets and BAC-111s are now a regular sight there as these two pictures by S. G. Richards show. The Comet is 'PDJ' and the One-Eleven 'TPJ'. Both would make challenging but interesting 'repaint' conversions from Airfix kits.



Two views of the Westland/Aerospatiale WG13 Lynx—the last of three helicopters to be built as part of the Anglo-French package deal. Orders for 350 aircraft of this type are expected shortly for the British Army, French and British Navies. A civil version should be flying in 1974.

and airfield familiarisation. Flights from there to Bedford, Liverpool and Glasgow have been made in connection with the automatic landing system.

G-AWZA was the first of the Trident 3Bs to arrive at Birmingham on January 11, 1971. After a few sorties the aircraft returned to Hatfield and no other Tridents were seen at Birmingham until January 28, when G-AWYZ arrived. Just before this, one of the other prototypes had collided with one of RAE's Comets at Bedford in a landing accident and 'WYZ' acted as a replacement for a certain period. The original prototype returned to Birmingham at the beginning of February, continuing the trials work for about a week. The second aircraft, 'WZB', made a brief appearance on February 25, followed in the middle of March by 'WZC'.

The Trident 3B differs from its predecessors by having a 6 ft 5 inches extension to the fuselage length and a slightly increased wing span. In addition to its three standard Rolls-Royce Spey engines the tail unit houses the RB.162 booster engine immediately below the rudder. This small auxiliary unit produces a thrust equal to ten times its own weight but is only 5 feet long and 21 inches in diameter.

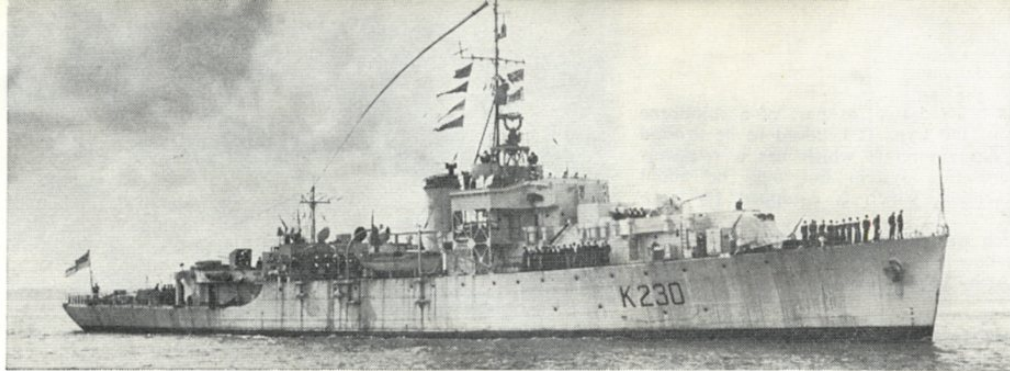

HMS Wear entering Portsmouth to pay-off in August 1946. She has a typical close armament of seven single 20 mm Oerlikons, in addition to her two single 4 inch (Wright & Logan).

# The 'River' class frigates

FIRST OF TWO ARTICLES

By Peter Hodges

AS the Battle of the Atlantic developed in intensity, it became clear that the existing types of warships engaged in escort duties were suffering from a variety of shortcomings. The 'Flower' class corvettes in their original form were found to be uncomfortable in the prolonged bad weather so prevalent in the North Atlantic, and were not much improved in this respect when a longer-hull version was produced. All did sterling work, but their maximum speed was less than that of a surfaced U-Boat. The escort Sloops were built to full 'warships standards' (ie, with twin turbine engines, a Fire Control system, etc) and although excellent vessels, could not be produced rapidly; while the Escort Destroyers—the 'Hunt' class—were similarly relatively complex and additionally had a restricted range.

Backing up these were the old 'V' and 'W' class destroyers—and an increasing number of the 'between war' destroyer classes—converted to Escort duties, but these, too, had their drawbacks—although again, all performed valiant work. The most useful were probably those 'V' and 'W' class ships converted to Long Range Escorts by the removal of one boiler room to increase oil fuel bunkering, but these old ships had never been designed for distant ocean work and were really too narrow-gutted for either comfort or efficiency. In any case the extensive alterations involved precluded more than a proportion being fully converted.

Destroyers always paid a heavy penalty in terms of range, for the sake of their high speed, and although they could be refuelled at sea from large warships, the Battle of the Atlantic was a small ship task. Major units, like cruisers and capital ships, did not form part of the convoy escort, except for the very early stages of the war. In consequence, most converted Escort Destroyers could only take a convoy a few hundred miles west of Ireland, and then return—perhaps with an incoming convoy.

To meet the requirements of an escort ship, suitable for long-range deployment, with a weatherly hull and an armament of limited AA but extensive A/S capability, the 'River' class were laid down. In the first instance, they were to be classed as 'Twin-Screw Corvettes', but eventually were called Frigates, thereby re-introducing a name long absent from Naval terminology. To speed and simplify production they were given reciprocating machinery and a gunnery installation which required neither a director nor a predictor.

Their displacement of 1,370 tons equalled that of the pre-war 'I' class destroyers; and though slightly shorter than these, their hulls were both beamier and deeper, making them more stable in bad weather conditions. The main engines developed 5,500 IHP, giving them a theoretical top speed of 20 knots. In practice, 18 knots was a more realistic figure; but in any case this 'sea speed' was quite adequate for the task they had to perform. What they lost on speed they made up for handsomely on operational range.

In these days of a severely depleted Fleet, it is difficult to imagine the size of the Royal Navy during the second world war. Fifty-seven 'River' class frigates were launched in British shipyards alone, as well as 12 in Australia and a further 44 in Canada. Many more Dominion-built ships were cancelled, but the complete order of British-built ships was fulfilled.

The first of the class was launched in November 1941 and the last British-built vessel entered the water in late 1943, although the launching of Dominion-built units continued into 1945. Of all these, only three were lost on the high seas through enemy action, and after the war, a large number were sold both to foreign navies and to the Mercantile Service. The latter fact alone speaks highly for their economy and sea-keeping qualities.

The building of the British ships was carried out by a number of the smaller commercial yards who were well suited to this type of uncomplicated warship, thus freeing the bigger firms for work on larger units. Exceptionally, four vessels were given geared turbines instead of reciprocating engines, but the Dominion-built ships had the standard machinery.

All the British 'River' class complied with their class designation and were named after what were, perhaps, the lesser-known streams in the British Isles. Who, for instance, would guess that *Odzani* was a British river? No doubt names like *Jed*, *Awe* and *Kale* brought a touch of home to erstwhile bank-clerks who by force of circumstances, found themselves on an open bridge in the bitter wind of winter, North Atlantic. The writer is no student of Commonwealth rivers, but careful examination of the names of some of the ships built abroad seems to indicate that not all were, in fact, named after rivers. Some of them departed from the planned armament layout, too, but the British vessels—with which we will deal in detail—had fairly consistent weaponry.

Post-war, the RN units mostly went for scrap in the mid-1950s, but one or two survived—*Meon*, until quite recently as a support ship for landing craft. One ship—HMS *Plym*—was given the doubtful privilege of being at the Nuclear Test carried out at the Monte Bello Islands in 1952, and here she was completely vapourised—truly a Nuclear-age end for any ship.

## STANDARD EQUIPMENT IN BRITISH-BUILT SHIPS

### Gunnery Armament

The 'River' class built in British yards had two single 4 inch HA/LA guns, the forward mounting in 'B' position on a longish extension of the forward superstructure, with a second 4 inch sited aft in 'X' position. The planned armament of ten 20 mm

Continued on page 514

**Key to drawings opposite:** (1) Section through quarterdeck—(a) Depth setting key. (b) Depth setting unit. (c) Diaphragm unit. (d) Firing spring case. (e) Detonator. (f) Primer. (g) Primer 'placer'. (h) Safety fork. (2) Section through overtern rail—(a) Inboard extension. (b) Ballast weight for heavy charge. (c) Stop bar. (d) Quarter deck. (3) D.C. ready to drop—(a) Resetting lever. (b) Hydraulic cylinder. (c) Piston rod. (d) Link. (e) Actuating lever. (f) Rocking lever. (4) First charge released. When hydraulic pressure was released, the second charge, pushing down on the resetting lever, reset the mechanism. A handle on the shaft of the actuating lever operated the gear in the event of hydraulic failure. (5) Part side elevation of thrower—(a) Wire strop. (b) Quick-release toggle. (c) Safety fork. (d) Exhaust port. (e) Explosion chamber. (f) Breech. (g) Firing pin. (h) Buffer liquid reservoir. (i) Carrier piston. (j) Filling plate. (6) Part end elevation of thrower—(a) End stop plate. (b) Buffer liquid reservoir. (c) Remote firing cylinder. (d) Buffer cylinder. (e) Striker pull-off link. (f) Local firing handle. (g) Carrier cross-head. (h) Tray. (7) 'Parbuckle' stowage—(a) Windlass. (b) Stop bar. (c) Ratchet and pawl. (d) Rollers. (e) Thrower tray. (8) 'Parbuckle' principle. (9) Ten pattern attack—(H) Heavy throwers and rail. (L) Light throwers and rail. (Note that range of Heavy thrower was slightly less than that of the Light).

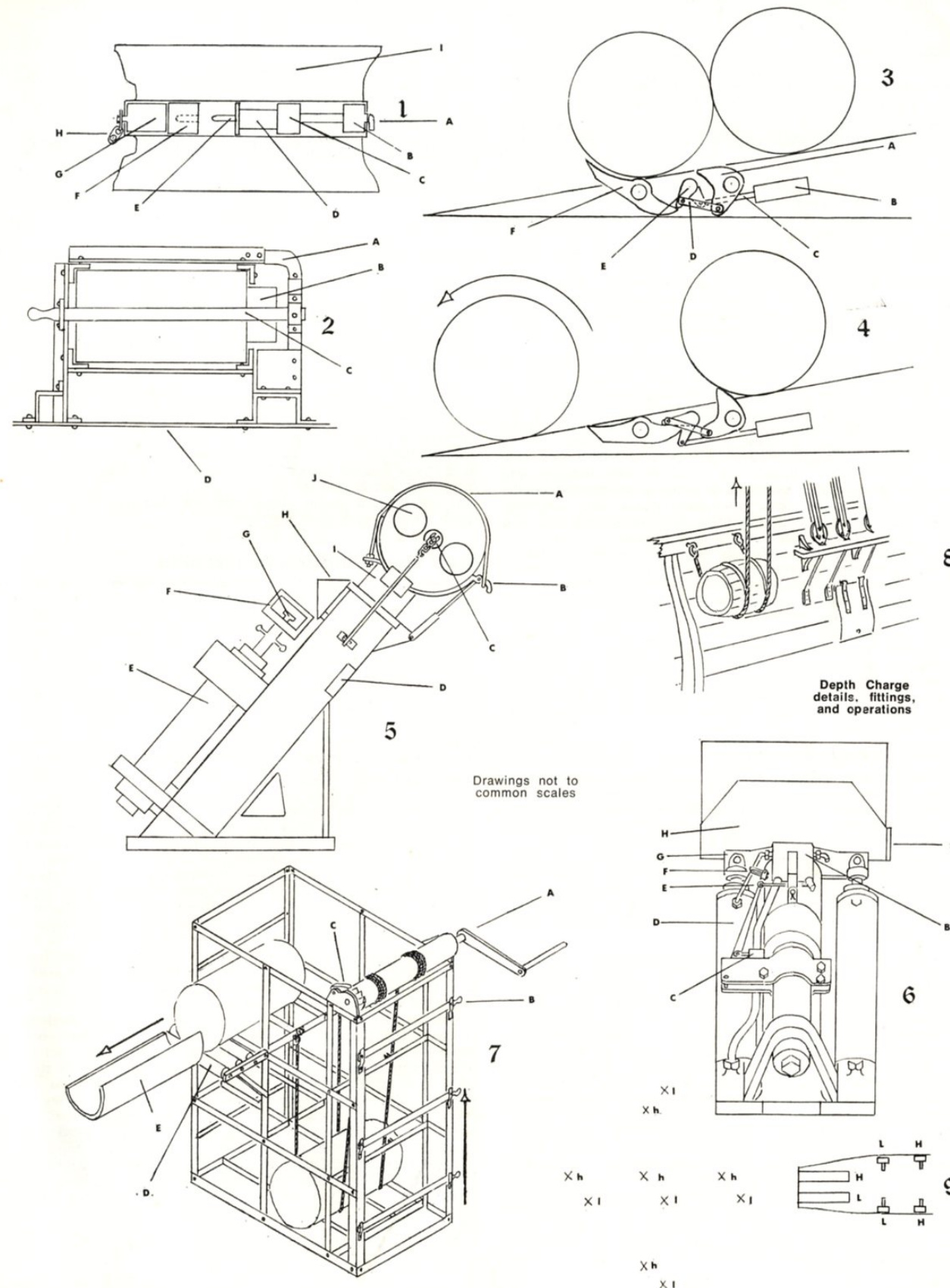

Drawings not to common scales

Depth Charge details, fittings, and operations



## 'River' class—continued

Oerlikons did not materialise, most vessels mounting at best only eight single guns. As more weapons became available the singles were sometimes doubled up, being replaced by power operated twin Oerlikons; and towards the end of the war a few units had 40 mm Bofors. On the whole, however, their guns were all simple hand-worked affairs which not only eased production and installation in the first instance, but also made maintenance simpler.

Unlike the elderly 4 inch which was mounted elsewhere in the Fleet, both gun and mounting in the 'River' class were comparatively modern in design, despite their simplicity. They were, in fact, specially designed to have that very attribute.

Because they had no real fire control system to direct them, the 4 inch could offer little more than deterrent fire in AA, but were quite capable of engaging U-Boats on the surface, the ships relying on their 20 mm Oerlikon armament to tackle aircraft at close range.

The Oerlikons were mounted in a variety of positions, but all ships had a 'single' on sponsons set high to port and starboard of the bridge superstructure. The sponson was supported by conventional lattice girdering, and a platform (at the more usual sponson position on 'B' gundeck level) extended to the ship's side beneath the gun position. A second gundeck spanned the ship abaft the funnel, between four mercantile-style ventilator cowls. Here, twin Oerlikons (or single 40 mm Bofors) were mounted to port and starboard in some ships, instead of the more usual single Oerlikons. Often there was a centre line Oerlikon abaft this position, super-firing over the after 4 inch and many of the class had an Oerlikon 'bow-chaser'.

To prevent guns from accidentally firing into the ship's structure, special arrangements were made on mountings with 'electric firing' to break the circuit when the weapon was aimed into its own ship. On purely hand-worked close-range weapons like the 20 mm Oerlikon, the barrel movement was constrained by a shaped rail which encompassed the mounting at such a radius as to bear about midway along the barrel. By careful design, the rail was arranged to allow the absolute maximum 'sky-arcs' for the individual weapon, at the same time physically preventing it from pointing into the ship's structure. These rails are frequently mistaken as supports for gun-covers, but clearly served a much more important purpose.

### The Anti-Submarine Armament

Since the 'River' class were designed for ocean anti-submarine tasks, we may take the opportunity of examining this aspect of the ships' armament. Previous articles in *Airfix Magazine* on second world war warships have fringed on the subject but it has never been dealt with in depth, so to speak.

**The Depth Charge:** This was the principle A/S missile in use during both World Wars, for although Ahead Throwing Weapons, in the form of the Hedgehog and Squid, saw service in specialised ships in World War 2, the depth charge continued to be the more general device in the Royal Navy for several years after the cessation of hostilities in 1945.

There were three basic types: the Standard depth charge, the Aircraft depth charge and the Slow Sinking depth charge. The first is the type to be discussed; the second was naturally special to its application for air-dropping; and the third was designed for use by Coastal Forces.

The Standard charge consisted of a steel cylinder 18 inches in diameter and 3 ft long, containing about 300 lb of explosive, but its all-up weight was over 400 lb. Several types of explosive were used, including TNT, and charges were 'coded' with narrow coloured bands to show their contents. A hollow tube ran through the axis of the charge, one end containing a removable primer, and the other, a removable 'pistol'. The 'pistol' consisted of a spring-loaded firing pin and detonator, and was operated hydrostatically via a depth setting device incorporating a diaphragm. It would not operate unless the equivalent water pressure corresponding to the depth set was reached. The primer fitted at the opposite end of the axial tube and was held away from the pistol by a safety device which was not released until the depth charge was discharged. After release, a spring pushed the primer into engagement with the detonator, and this safety device ensured



*HMS Helmsdale continued to serve for some years after the war as an A/S Trials Ship. She had no gun-armament, but carried twin Squid Mortars on her forward 4 inch gundeck, and retained the D/C arrangements aft.*

that the charge would not explode prematurely—or if the ship sank.

On reaching the set depth, the hydrostatically operated 'pistol' fired the detonator; this in turn fired the primer, which itself fired the main explosive charge.

**The Deep Depth Charge:** There were two reasons governing the introduction of this type. In the first place it was necessary to increase the sinking rate of the Standard depth charge so that a 'layer' effect could be achieved; and in the second, as submarine pressure hull design improved allowing the vessel to go very deep, it became equally important to be able to blast it at the extreme range of its dive.

These facilities were achieved by adding a weight to the standard charge making it about 550 lb all-up, and suitably modifying the 'pistol' depth setting.

It will be seen in due course how both Standard and Heavy depth charges were used together.

### Depth Charge Discharge Arrangements

**Chutes:** The earliest form of dropping gear consisted of a stern chute, which should not be confused with the later 'trap'. The chute held two or three charges, each secured by a double wire lanyard, fitted with a quick release device. Sometimes, similar chutes were fitted to drop depth charges athwart-ships from the ship's side and all these were operated locally. The chute principle persisted through the second world war, but was then restricted in the main to Coastal Forces vessels. Because they were small craft, it was possible to arrange a simple remote operation of the chutes by leading wire cables to levers on the bridge. Coastal Forces often used Slow Sinking charges offensively against opposing E-Boats, and dropped them from wire-operated chutes.

**Rails and Traps:** Between the wars, the usual over stern dropping gear took the form of a set of rails inclined to a slope and holding three depth charges. Reloads were carried close-by on support chocks and loading was by davit. The rear-most charge was held in position by a pair of curved arms carried on a transverse shaft, and when this was turned—either by a hand lever or remotely through a hydraulic cylinder—the arms dropped, allowing the depth charge to roll off the rails. As the release arms dropped, a second pair one 'step' inboard rose to hold the next charge, so preventing a double drop. Resetting the gear actuated the arms in the reverse sense and the second charge rolled to the overboard position. Sketches show the sequence of operation.

There were several marks of Trap to suit special requirements (for instance, when sweep gear was also fitted on the quarter deck) but the principle remained the same.

The standard set of World War 2 over stern rails held six depth charges. The outboard section—terminating in the trap—held three DCs and was inclined at 10 degrees, and the second section, also holding three, was inclined at 1½ degrees. Removable stop-bars were fitted outboard, inboard and between the two rail sections to prevent the whole outfit of charges from bearing on the trap gear or rolling inboard on to the deck. Frequently, a wooden wedge was knocked between the stop bar and adjacent charge to prevent bumping in a seaway.

Additional sections of 1½ degree rail could be added inboard in multiples of three charges to a total of 18, each with its own stop bar. In many A/S ships, double tier rails were fitted and in this case the trap was on the top level and the lower merely held reloads. Rail loading was by davit and when twin double-tier rails of maximum length were carried they held a total of 72 charges.

**Depth Charge Throwers:** Up until the middle of the first world war, the chute method was the only means of dropping depth charges, and there was no means of achieving a 'spread' of explosions. The Admiralty asked several commercial companies to investigate this problem, and the bulk of the pioneer work was carried out by Thornycroft's, the famous Southampton destroyer-building firm. From their experiments, the first successful depth charge throwers were evolved and were fitted in quantity throughout the small ships of the Fleet. They were also built under licence by foreign governments, but one country—which shall be nameless—simply copied the Thornycroft design (even to the 'GR' monogram) but studiously avoided royalty payments!

The original thrower—the Mk II—used a 'carrier' consisting of a stalk fitting into the barrel. The carrier terminated in a curved carrier plate to which the charge was lashed, and both carrier and charge were expended together. The carrier idea was thus expensive in material and wasteful in space, so Thornycroft's took up the challenge and came up with a redesigned thrower. This was the Mk IV, and many thousands were made during World War 2. In this mark, the carrier was limited in movement and was not expended.

To reduce the shock of discharge, the cartridge was detonated in an explosion chamber. The cordite gases passed from this into the barrel itself, thrusting the carrier piston outwards as they expanded. Towards the end of its movement the carrier piston allowed the gases to escape from exhaust ports and finally it was brought to rest by a pair of hydraulic buffers. It then ran back to the inboard position by gravity.

The depth charge was secured into the carrier tray by a wire strop with an automatic release; a second strop fixed at one end to the barrel was clipped to the Primer arrangements, keeping them 'safe' until the depth charge was discharged.

**Thrower Loading Arrangements:** These at first were similar to the re-loads for the early chutes and three-charge rails, but were improved during World War 2. Each thrower then had a stowage rack for six charges carried in two vertical trios. The upper outboard position was in line with the depth charge carrier tray and had a short bridging rail fitted with steel rollers. The depth charge was moved sideways from this position directly on to the tray ready for firing, and the inboard charge in the rack rolled forwards to the top outboard position. To raise the charges up to the top tier, the stowage was provided with a simple windlass which lifted a charge by the 'Parbuckle' principle. This process is more easily described graphically and the sketches should make it clear. In addition to the Parbuckle-gear, each stowage also had its own davit.

**Depth Charge Attacks:** With the advent of the early throwers the standard attack became the 'Five Pattern', two charges being fired from the throwers and three dropped from the single rail astern to form a roughly cross-shaped spread. During the second world war the complete installation was doubled up—that is to say that ships had four throwers and double rails and traps. The attack became a 'Ten Pattern'—four charges from the throwers and six from the rails. With each thrower stowage topped up and twin 18 charge rails, it follows that there were 60 depth charges on deck—sufficient for six successive 10 pattern attacks—and extra depth charge stowages were often added (by the two tier rails, for example) as well as in other upper deck rail like racks. To achieve a 'layering' effect, one rail (usually the port) and the

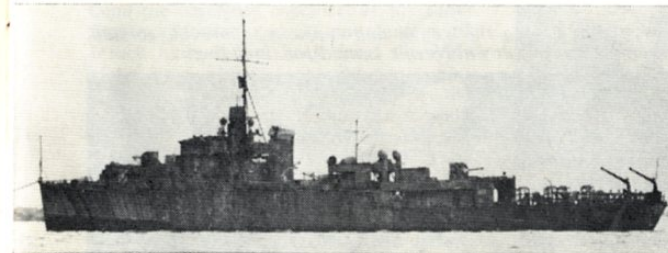

*Notice the prominent minesweeping davits on the quarters of Ness, and the extensive depth charge stowages. The photograph dates from June 1950, when her working days were over. (P. A. Vicary).*



*The last 'River' class to be actively employed in the Royal Navy was HMS Meon. Notice the revised gun armament, exclusively of close-range weapons, and particularly the special Oerlikon sponson above the post-war pendant number. As an HQ ship for landing craft, she had an extensive radio system, and wore the 'Combined Ops' badge on her funnel beneath the 'leaders' band.*

forward pair of throwers discharged 'Heavies' so that the complete pattern resembled one cross shape of five explosions superimposed upon another.

Other patterns were fired to suit the particular installation. An 'Eight Pattern' was used on ships with two rails, but only two throwers, and the 'Seven Pattern' by ships with four throwers and one rail. The 'Five Pattern' was retained for doubtful 'contacts' so as to avoid unnecessary expenditure of DCs. In addition, there was also the 'Creeping Attack' perfected by Captain Walker to plaster deep submarines. This expended some 26 charges and lasted over half a minute. It involved the rapid reloading of the throwers after their first firing and needed much physical effort, team work and good drill from the depth charge crew who numbered over 30.

**Pattern Control:** This was decided by three factors. The first was the positioning of the throwers in relation to the stern and to each other and was standard for most ships. The second was the automatic firing/dropping interval, achieved by a clock-style mechanism, which in making one revolution, operated electro-hydraulic valves in the firing system. The firing cycle was normally initiated by the Asdic at a predicted time, but this control could be over-ridden by alternative means. In the event of an equipment failure, local firing was carried out by stop watch on the quarterdeck.

Thirdly, the overall spread depended upon the speed of the attacking ship and was tabulated for 15 knots, but could be dropped at anything over 10 knots. The exception was the creeping attack, but this was restricted to very deep attacks, when the damage to one's own ship from the depth charge explosions was minimal.

The throwers were set at a fixed elevation of 50 degrees and were angled slightly astern of the beam. In some small ships, where quarterdeck space was at a premium—the 'Hunt' class for example—the forward pair of throwers was sometimes sited towards the waist, in which case they were angled further astern so as to produce the same dropping pattern.

The Asdic instruments which formed the Anti-Submarine 'predictor' were often housed in a small A/S 'House' in the rear of the bridge under the close scrutiny of the Torpedo Officer. He was the professional expert in all matters relating to Torpedo, A/S and mine warfare, and was the Captain's right-hand man in this respect.

### Ahead Throwing Weapons

The great drawback of the depth charge attack lay in the fact that the surface ship had, of necessity, to pass over the target before releasing her charges. This had the double effect of, firstly, enabling the U-Boat Commander to make rapid last minute alterations of course and depth, and secondly of making it very likely that Asdic 'contact' would be lost.

These problems were, of course, well realised; and development began on a weapon which would fire ahead of the attacking ship. Several schemes were tried, but finally the back-room boys came up with the Hedgehog. This was a spigot mortar—implying that instead of fitting into a barrel, the bomb fitted over a spigot. Twenty-four such spigots were carried on girders in four longitudinal rows of six. The girders were slung in fore-and-aft trunnions and were connected by a link bar, allowing a tilt up to about 45 degrees each side of upright. This enabled the weapon to be compensated for ship-roll, and also provided a small deflection, or 'aim-off' facility.

*Continued on page 549*

# Medieval Siege Artillery

WEAPONS FOR WARGAMES OR DIORAMAS WHICH CAN BE MADE FROM Balsa Wood and ODDMENTS

By Terence Wise

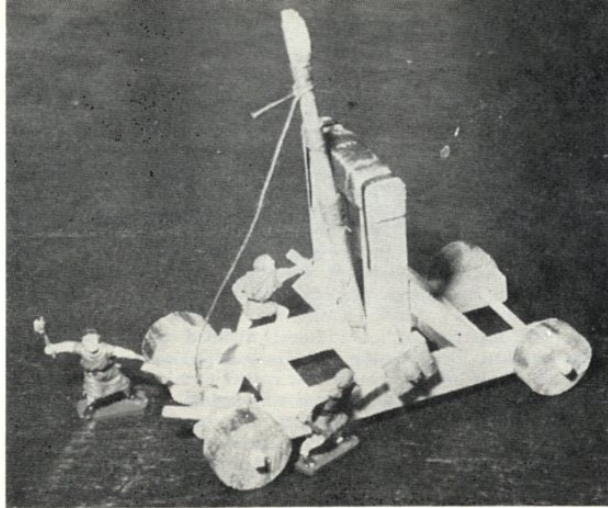

WHEN an army decided to attack a castle it had a choice of three methods: over the walls by assault, under them by mining, or through them by means of a breach made by siege artillery. Of these an artillery bombardment was probably the best choice, for with siege artillery it was possible to stay out of range of enemy fire and methodically reduce the defences until an assault could be made at small cost. From the defenders' point of view, prolonged bombardment was one of the greatest threats, for the only sure defence lay in attack—a sally to destroy the machines—thus abandoning the advantages of a defensive position.

However, the use of siege artillery involved much work before a bombardment could begin, for the machines were too big to be moved any great distance and had to be built on the site. Teams of horses and wagons were needed to bring timber and rocks to the camp, while perhaps five master carpenters and 50 labourers might be required to build the machines. On the credit side, once the machines were constructed, it was not unusual for the besieged to surrender on terms, aware that their defeat had become inevitable.

The mangonel, or catapult, is mentioned as early as 800 BC and it remained in service until the 12th century. It worked on a torsion or twisting principle. A wooden arm, with a spoon-shaped end, had its other end thrust into a web of ropes which were secured to a frame. The

ropes were twisted by means of capstans at the sides of the frame, the arm was winched down, and a stone placed in the spoon. When released, by a slip rope or hook and eye system, the arm whipped up to strike a padded bar, catapulting the projectile in the same fashion as a paper wad being flicked from the end of a ruler, which is allowed to strike the edge of a table. The mangonel was ideal for siege warfare until the 12th century, when the advent of stone castles, which later developed thicker and higher walls, called for a more powerful weapon with a higher trajectory. The result was the trebuchet. Basically this consisted of a frame with a cross bar on which pivoted a long arm, a quarter of which projected towards the enemy. To this shorter end was attached a container filled with weights, while the other end bore a sling. The sling end was winched down, a missile placed in the sling, and the arm released suddenly. The range could be altered by moving the weights on the short extension. The trebuchet was made in various sizes, some quite small, others large enough to hurl 300 lb rocks three hundred yards. Greek fire was sometimes tossed into castles, also dead horses (germ warfare), and occasionally prisoners or hostages (psychological warfare)! Below are instructions for making these two machines. They are to a scale of 5 mm = 1 inch, on the basis that medieval man was on average 5 feet tall and Airfix figures are usually 25 mm high overall. Size is not too critical, however, so you

could reduce the dimensions given by about one-fifth if you wish to keep these weapons to the same scale as modern 1:76 scale tanks and guns.

## MANGONEL

Materials needed:  $\frac{1}{4}$  and  $\frac{3}{16}$  inch balsa, 15 and 5 mm dowel, matches, elastic band, thread, ribbon or fine textured material, card.

Cut two 80 mm lengths of  $\frac{1}{4}$  in balsa for the frame sides and two of 40 mm for uprights. Drill axle holes 5 mm from each end of the former and 5 mm from one end only of the latter. (A sharp 2 inch round nail will 'drill' balsa.) Glue the uprights to the base lengths at the centre, holes to the bottom. Glue three 20 mm lengths of  $\frac{1}{4}$  inch balsa between the two halves of the frame at the centre and 20 mm from the centre in each direction, also a 35 mm length across the top of the uprights. Use  $\frac{3}{16}$  inch balsa as struts in front of the uprights, placing the balsa across this part to cut at the correct angles.

Drill a 2 mm hole through the centre of the 15 mm dowel and cut four pieces 6 mm thick for wheels and four 3 mm thick for capstans. The latter are squared off to 10 mm. Round off two matches and push one through the front axle holes. The other is pushed through one side at the rear, two capstan squares threaded on, then pushed through the far side. The squares are glued to the axle. The wheels are now glued on the axles,

short lengths of match being glued in the outer faces to represent axle hubs.

Thread a needle, including in the loop a 30 mm elastic band. Thread this through a capstan square and glue a small wedge across the hole before pulling tight. Now thread the band through both uprights and the remaining capstan square, finishing off with another wedge before cutting the thread. The band is now under sufficient tension for you to twist it by turning the capstan squares.

Take an 80 mm length of the 5 mm dowel and taper it to a 10 mm block which is then carved into a spoon shape. Bind the arm with thread every 10 mm and insert 5 mm of the thick end through the elastic band. Cut eight 8 mm lengths of match, thin them by a third, and glue them to the capstans for handles. (These squares had holes to which the handles were moved in turn, a ratchet preventing slipping.)

Pad the cross bar with ribbon or some other fabric binding in place with thread. Two 35 mm lengths of card 2 mm wide are then glued over the beam and the uprights and painted black to resemble iron brackets. Tie the thread below the spoon, the other end going to the capstan axle and the slack being wound on. Wind up the side capstans, 'winch' down the arm, load a missile into the spoon and fire. The machine will jump slightly, a characteristic which caused the Romans to name it the 'Wild Ass'. Depending on the torsion used, you should achieve a satisfactory range for realistic model sieges. My record to date is 6 ft 1  $\frac{1}{2}$  inches, in scale a range of 367 feet. Care should be taken in selecting 'missiles' which will not damage household fittings or injure people if the shots go astray.

## TREBUCHET

Materials needed:  $\frac{1}{4}$  and  $\frac{3}{16}$  inch balsa, pins, 15 and 5 mm dowel, thread, matches, card, scrap lead, Plasticine, ribbon.

Two 130 mm lengths of  $\frac{1}{4}$  inch balsa make the base sides, two 90 mm lengths form the uprights, and one 100 mm length forms the main cross beam of the base. Join the base sides and cross beams with halving joints at the 50 mm mark on the base sides and 10 mm each side of the centre mark on the cross beam. Glue the assembly together, at the same time positioning two 20 mm lengths of  $\frac{1}{4}$  inch balsa 5 mm back from the ends of the base sides at front and rear.

Cut pairs of supporting beams for the uprights from  $\frac{3}{16}$  inch balsa, measuring from the top of the uprights to (A) front cross beam, (B) rear cross beam, (C) the ends of the main cross beam. Allow the ends of A and B to project above the uprights: later they will be trimmed to take an axle. When fixing these struts, insert a 20 mm length of balsa between the uprights temporarily to obtain the correct gap.

While this frame is drying, prepare the

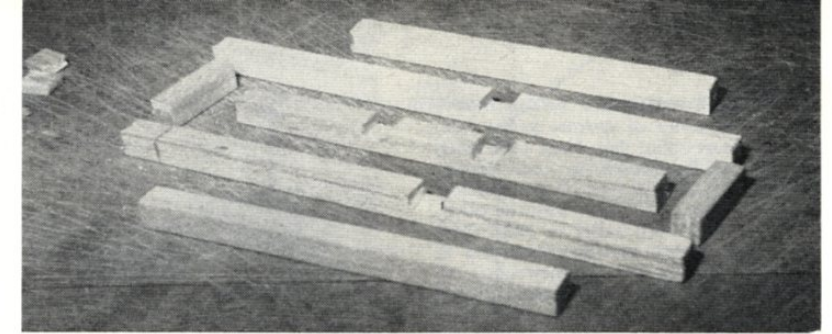

Opposite page, top: The completed mangonel. If you have the hook and eye system used for the trebuchet, the arm could actually be winched down as in real life. Above: Parts for the base and two main uprights of the trebuchet, ready for assembly. Below: This shows the full framework assembly of the trebuchet, also the basket arrangement on the arm. Bottom: Another view of the basic framework. Here can be seen the arm and sling assembly and the eye arrangement connecting arm to winch.

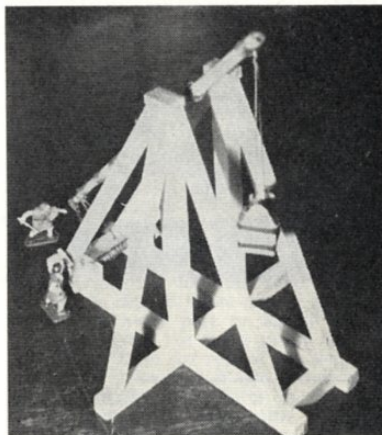
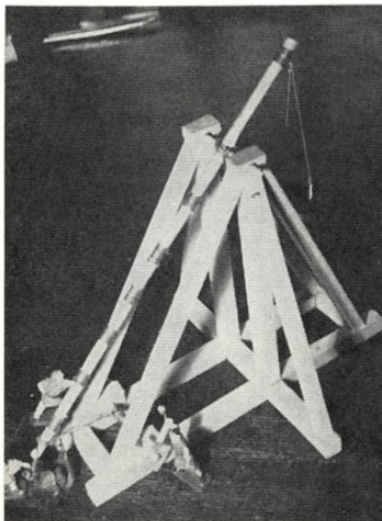

Glue and reinforce with thread applied in figure of eight fashion.

Cut a 10 mm block of  $\frac{1}{4}$  inch balsa in half lengthways and make grooves across their width to receive the axle. Glue these caps on top of the uprights after trimming the struts to receive them and placing the arm in position. Cement two pieces of  $\frac{1}{4}$  inch balsa 15 mm long in the angles of the rear struts and base and drill holes in the centre of the blocks. Cut two 3 mm thick pieces of 15 mm dowel and make them into capstan squares as for the mangonel. Push a rounded match through one block, thread on the capstan squares, then push the match out the far side. Glue the squares to the axle and attach short lengths of match to the squares for handles.

Make a small box, 10 mm square, from card, allowing a triangular extension on two sides. Bind the box with card strips painted to resemble iron, fill the box with scrap lead and top with Plasticine moulded to look like rocks (without this the lead will jump out when firing). Thread is tied to the triangular lobes, the other ends being attached to the thick end of the arm, allowing sufficient slack for the box to rest on the ground when the sling end of the arm is straight up.

Make a loop with thread and tie this to the sling end of the arm. Cut a pin in half, bend the head end into a hook and fasten thread to the head. Secure the other end of the thread to the winch axle. Connect the hook to the loop on the arm and winch down the arm.

Take a piece of ribbon 35 mm by 10 mm (glue the edges to prevent fraying) and tie thread to both ends, bunching the ribbon to form a sling. Tie one end to the arm and make a 10 mm loop of thread at the other. Hook the loop over the notch, load with a pellet and . . . Fire! Maximum range achieved with my model scaled up to 330 feet. (The pellet was Plasticine and three times the size of the head of an Airfix OO/HO figure.) This was a rather disappointing result, but at least I can span a wargame table! Of course, the range may be increased by reducing missile size, or increasing the weight in the box.

Airfix Robin Hood set figures can be used as crewmen for these monster weapons.

Below, left: Basic framework for the mangonel with holes drilled. Below, right: Fitting the 'ropes' and capstans to provide torsion. Note the thickness of the wheels, to prevent the machine becoming bogged down. Needle is used for threading.

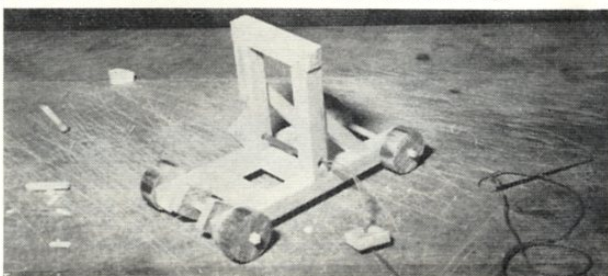
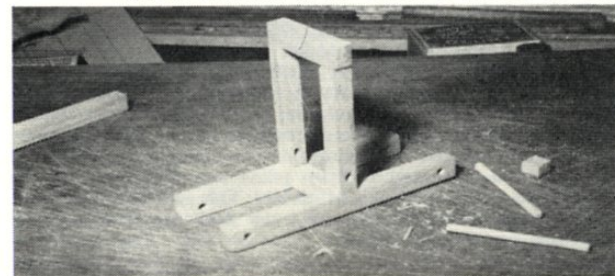

**T**HIS small station is a further model in the series of narrow gauge railway structures that has been appearing over the last few months in *Airfix Magazine* and its size and type of construction have been chosen to fit in with the other buildings. It is even easier to build than the earlier models I've described and is especially suitable for the newcomer to scratchbuilding. With this in mind I have illustrated the steps in construction in a series of stage by stage photographs which, with their accompanying texts, will, I hope, be self-explanatory.

The model is based on two stations on the Tallylyn Railway, Abergynolwyn, old station, and Dolgoch shown in the photograph.



This is the model station you are building; it is based closely on Abergynolwyn, Tallylyn Railway, shown opposite, but the author's model has a slightly different platform to suit his own particular layout.

# Narrow Gauge Station

ANOTHER SIMPLE LAYOUT PROJECT BY MICHAEL ADDRESS

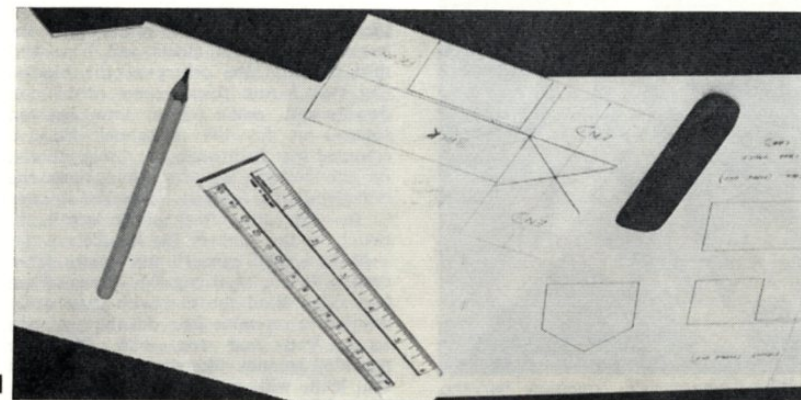

**STAGE 1:** Mark out the front, back and ends on to 60 thou thick plastic card using the plans provided as a guide. Make the pencil lines bold and clear as they tend to rub off this material rather easily.

**STAGE 2:** Now cut these parts out using a fine saw. Note that I left the front and back pieces joined until after I removed the large doorway section from the front. This way there is less risk of breaking the thin strip left above this opening. I cut the doorway out by sawing the vertical cuts, then cutting part way through along the top both front and back, using a knife. I then bent the plastic card along this line until the piece broke away. This break may need a little filing to make it true and square.

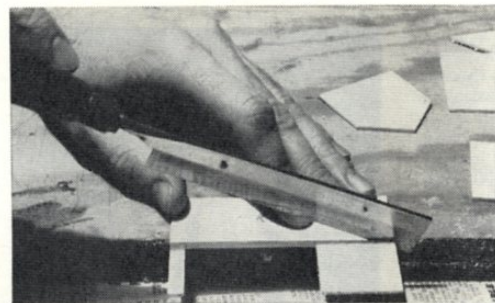

2

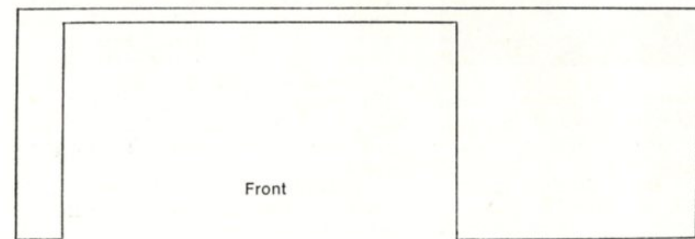

Front

Ends (two needed)

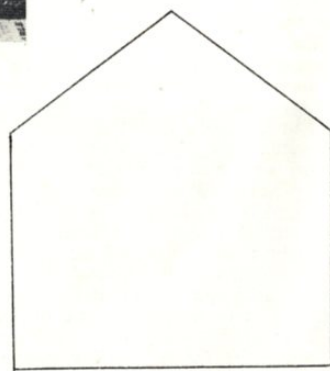

Pictures are keyed to correspond with constructional stages in text.

**STAGE 3:** Use the four walls to mark out the facing pieces of Slater's embossed stone course Plastikard. As the courses of the different walls must coincide it is important to cut along the lower edge of the sheet in one of the grooves between the courses before marking out. Then mark each piece out (on the back of the embossed sheet for ease), making sure that the bottom edge of each wall will be at the bottom edge of the sheet. Allow 3 mm extra at each side of the two end pieces. This is so that when the ends fit within the front and back the facing will cover the exposed end surfaces of the front and back. When marking out allow a little surplus (except at the bottom) as this can easily be trimmed off afterwards as shown here, to give an exact fit. Now cement the facings to the walls. If you

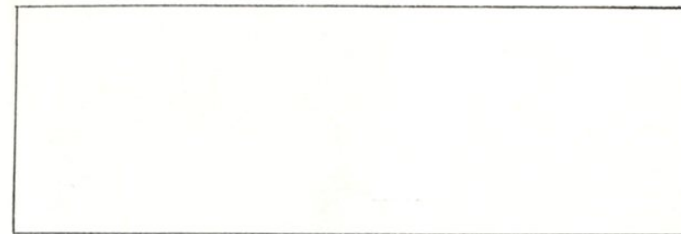

Back

All drawings full-size for model

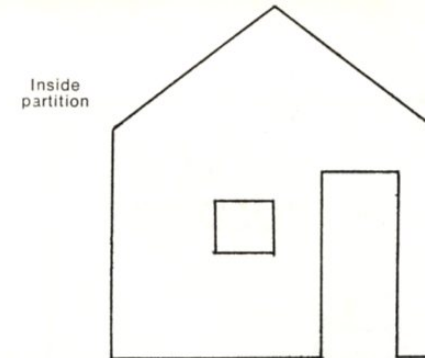

Inside partition

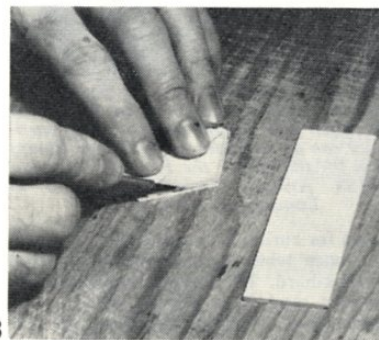

3

cannot get this 'stone' Plastikard locally it can be had by post from Jones Bros of Chiswick at 24p a sheet. An alternative is to use the excellent Faller embossed stone card sold in some model shops.

**STAGE 4:** The partition between the booking office and the waiting area is cut from 20 thou thick plastic card to the pattern shown full size above. Cement a piece of plastic card slightly larger than the doorway behind this opening to represent the closed door and a strip of plastic beneath the small window opening. The four walls and the partition can now be assembled. Fit triangular pieces of scrap plastic card in the upper corners to strengthen the structure and to ensure squareness. If you wish, the inner walls (left-hand end and rear walls only) can also have a facing of the embossed stone course material. I didn't do this as these surfaces are not readily visible in the finished model. Trim any excess of the facing material at the corners and fill any cracks visible at the joins with a little filler. When this has set hard use a fine file to remove any excess filler and to continue the grooves between the courses of stones round the corners. This isn't as tedious as you might think and a little

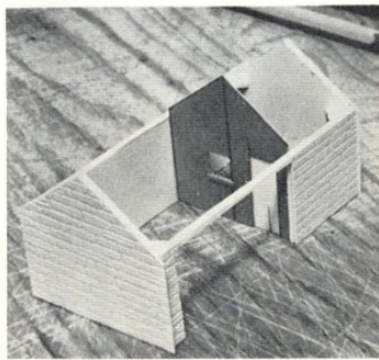

4



care with details such as this will do a great deal towards giving the impression that the model is really built up from individual stone blocks instead of merely being covered with an embossed facing.

**STAGE 5:** The roof is fitted next. Cut two rectangles of 1 mm thick card 31 mm by 95 mm and cement these in place to form the basic roof. To represent the slates cut a number of 5 mm wide strips of thin card. Make a series of cuts about 1/4 of the way across each strip from one edge, spacing the cuts about 3 mm apart. Cut two strips about 2 mm wide and cement one of these along the bottom edge of the top surface of one side of the roof. Then glue one of the wider strips on top of this with its lower edge along the lower edge of the roof. Then lay further strips along so that each overlaps the upper half of the one below. This gives a good representation of individual slates. Carry on until you reach the top edge of the roof and then repeat the process for the other half of the roof. Finish the roof by adding a capping strip of the thin card. Broken, missing or slipped slates can be modelled by cutting away part or all of a slate before applying the strips or by separating a slate from the rest of the strip and cementing it so that it lies low in position. Modelling the slates in this way gives a good finish with some relief and it is much more effective than using slate paper. The extra work involved is well worthwhile as from the usual viewing point the roof of a model building is the part which is most obvious. Cut strips of 2 mm width from 1 mm thick card and cement them under the eaves at each end of the building. I painted the walls grey, the roof and the interior of the booking office matt black, and the partition

brown. The pillar in the opening at the front of the structure is a length of 3/32 inch square balsa.

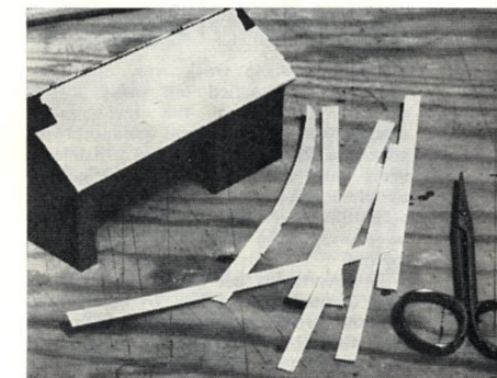

**STAGE 6:** I wanted a typical platform for my station and the prototype pictures show exactly the sort of platform so often seen on narrow gauge railways. I cut a rectangle of 60 thou thick plastic card about 7 1/2 inches by 3 inches (though you can choose the size to suit the space you have available, within limits). Along the front edge make a series of short cuts with a fine saw to simulate the gaps between stones. With a knife, cut away a little plastic to give some irregularity both in the edges of individual stones and in the positions of the stones relative to each other. Then cut some strips of the same material and make saw cuts in a similar way. Next I cemented two layers along the underside of the platform piece at its front edge as in the photograph. I

Continued on page 542

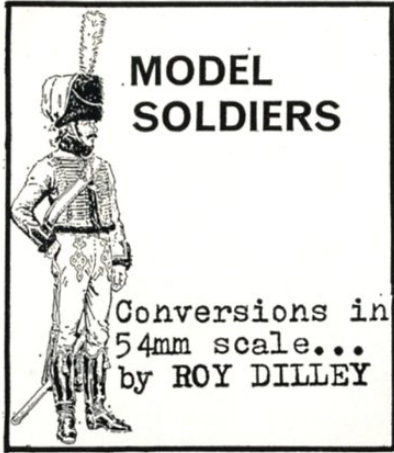

# MODEL SOLDIERS

Conversions in 54mm scale...  
by ROY DILLEY

As I have stated in previous articles, anything that can be worked and bonded satisfactorily is valid in the creation or conversion of models, and some startlingly realistic effects can be achieved with what would appear at first glance to be unlikely substances.

Only a few years ago metal, usually an alloy of lead or tin, was virtually the only material from which models were produced commercially. Adhesives available to the modeller tended to be unreliable, and in consequence the success or failure of a conversion turned upon the degree of skill with which one could employ a soldering iron, whilst obviously the range of materials to be used was confined to those which could be soldered to lead alloys.

Some exquisite work was, and continues to be carried out using metals exclusively, but with the development, dependability, and general availability of adhesives, it has now become possible to press into service a wider variety of materials than has previously been the case, thus enabling form and texture to be conveyed in a model with greater facility.

The increasing use of plastics, particularly of the 'hard' variety, by commercial manufacturers has also contributed to the ease with which models can be assembled and converted. All in all, therefore, today's enthusiast has at his command a considerable diversity of media from which to create his models, yet it is always an exciting moment when he discovers or is introduced to a new modelling material or technique.

My conversion subjects this month make use of two substances which I have added to my list of 'approved materials' only comparatively recently, the first being Isopon resin, and the second Milliput, an epoxy putty.

Isopon was introduced to me as a modelling medium by my good friend Arthur Woodford, who employs it to great effect in the creation of his enchanting replicas of 'military' females throughout the ages. This resin is mixed with a catalyst to form a substance of heavy,

cream-like consistency, which can then be used to build up areas on a model, or be applied as a coating over tissue-paper, cloth, or other porous material to form drapery or clothing. It will adhere tenaciously to most other bases, except plastic, and hardens in a quarter of an hour or so into a state in which it can be sanded, cut, filed or drilled with ease. After several hours, it dries completely, and will accept paints and varnishes with no adverse effect. Thin sections tend to be rather brittle, but if such parts as arms and legs are supported by an internal wire armature, they become as least as strong as the same sections would be in metal. I find it particularly useful when used as a coating to stiffen tissue or linen draperies on a metal basic figure. This compound can be obtained from most motor accessory stockists, and comes in two grades, coarse and fine, the former being more suitable for building up surfaces and equipment, whilst the latter is ideal for coating purposes.

The second new material, Milliput, is an epoxy compound in which equal quantities of two agents are thoroughly mixed together to form a putty-like substance which can be applied like Plasticine to most other materials, including hard plastic. It forms a very strong bond, and sets hard enough to work within two or three hours. It has a further advantage in that setting can be accelerated by the application of a modest degree of heat, such as that given off by a hair-dryer set to hot, or a fan-heater. Such heat will cause hardening to take place in only a few minutes, when the putty can be worked with care. Again, it takes some



This most attractive pair of figure conversions perfectly captures the flavour of the Boer War period—the faces in particular are an excellent study. These figures won for the author the Turpin Cup at the BMSS Annual Competitions held in London on April 25 last.

hours for curing to be completely effected, but, once achieved, the resultant material is rock-hard. Its uses in modelling are obvious, and it is ideally suited to all applications involving building up surfaces, and the addition of headgear and equipment. My sample of this useful aid was obtained from my local model shop, Passmores of Coulsdon. Unfortunately, the instruction leaflet gives no other details than the brand name, but I am currently attempting to find out the manufacturer's name and address, together with any main stockists, and will publish this information as soon as possible.

I have chosen to depict another 'out

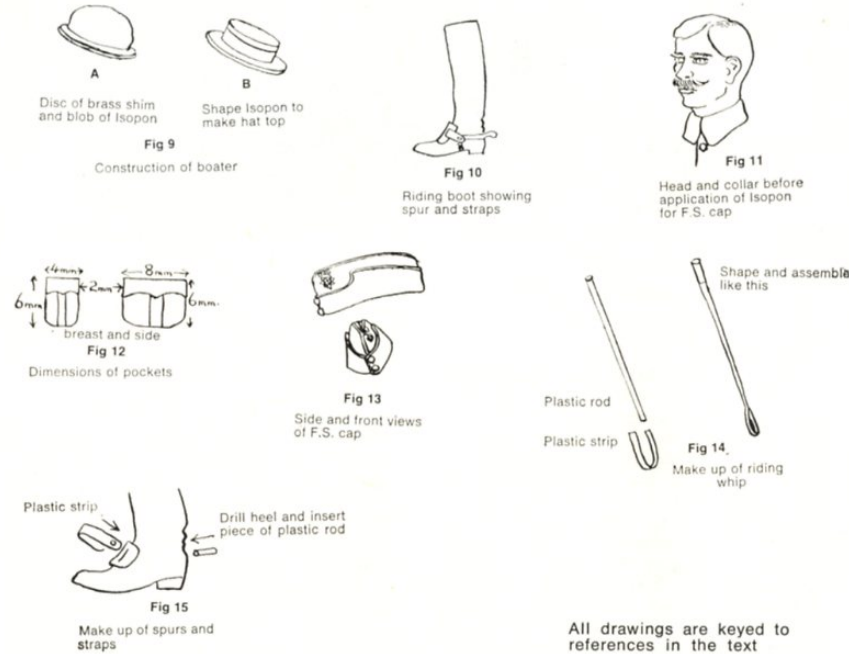

All drawings are keyed to references in the text

of action' situation this month, and have introduced a little feminine interest for good measure. The figures represent an Army Nursing Sister escorted by an officer of the Life Guards, taking an afternoon stroll at the time of the South African or Boer War 1899-1902. Such a couple might well have been seen in Cape Town during those years, since many Nursing Sisters were stationed at No 1 General Hospital, Wynberg, very conveniently situated for a visit to the city on an afternoon off, being only an eight-mile tram-ride away. Discipline was very strict, and female virtue was rigidly safeguarded, so the Nurse's escort would probably have been a relative or close family friend. Although social intercourse of an officially approved nature was scarce, the Sisters seemed quite content to occupy such spare time as they had in such innocuous pursuits as photography,

visiting neighbouring towns, and exploring areas of the surrounding veldt, no doubt in thoroughly chaperoned parties. Ian Hay, in his history of Army Nursing Services, records that many Sisters also became philatelists to a greater or lesser extent, sending home South African stamps for the benefit of younger members of their families.

A considerable expansion of the Army Nursing Service took place as a result of the Boer War. At its commencement, the entire ANS establishment comprised: one Lady Superintendent, 19 Superintendent Sisters, and 68 Sisters, whilst by the close of hostilities some 1,800 trained nurses had been sent out to South Africa.

Both figures are depicted in 'walking-out' dress, the Sister wearing rather a smart little straw 'boater' with a gay scarlet ribbon, her headgear when on duty being a white veil bound round the

hair and falling to the shoulders at the back. The male officer sports a coloured field service cap, and has left off his Sam Browne belt, a widespread off-duty practice, if perhaps a little casual. His foreign service tunic, of khaki-drill cloth differs from the regulation pattern in having pleated side pockets in addition to the standard breast pockets, whilst it is fastened by brown leather buttons instead of the more usual brass ones. He carries a long riding switch, and moustached, booted and spurred, is typical of the officers of that period.

The selection of basic figures for conversion presented something of a problem, but I finally settled on one of Cliff Sanderson's delightful females for the Nursing Sister, whilst Historex provided the necessary pieces for the man.



## CONVERSION I

Army Nursing Sister conversions require one Sanderson nude girl with British lancer cap. This, of course, is a metal figure and will require careful handling to avoid bruising or blurring of some of the delicate detail of features and hands. Commence the conversion by separating the left hand from the front of the body, and bending the arm outwards to assume the position shown in the photographs. Remove the sword from the right hand, and trim up the fingers on both hands to avoid the clumsy appearance left by the processes of separation. Next, using a fine jeweller's saw, or fret-saw, cut off the lancer cap, following the line of its lower edge (Fig 3). The hair is now trimmed off from around the neck, and shaped to the back of the head (Fig 4). At this stage, it is convenient to turn the head slightly to one side, and for this operation it should be wrapped in a piece of cloth, 'shammy' leather, or soft lead, before applying pressure with the jaws of a pair of long-nosed pliers. This will prevent any bruising of the engraved face detail.

Now mix a small amount of Isopon with a drop of the catalyst, and apply it to the back of the head. It will adhere very well to the metal, and when it has

Continued on page 540

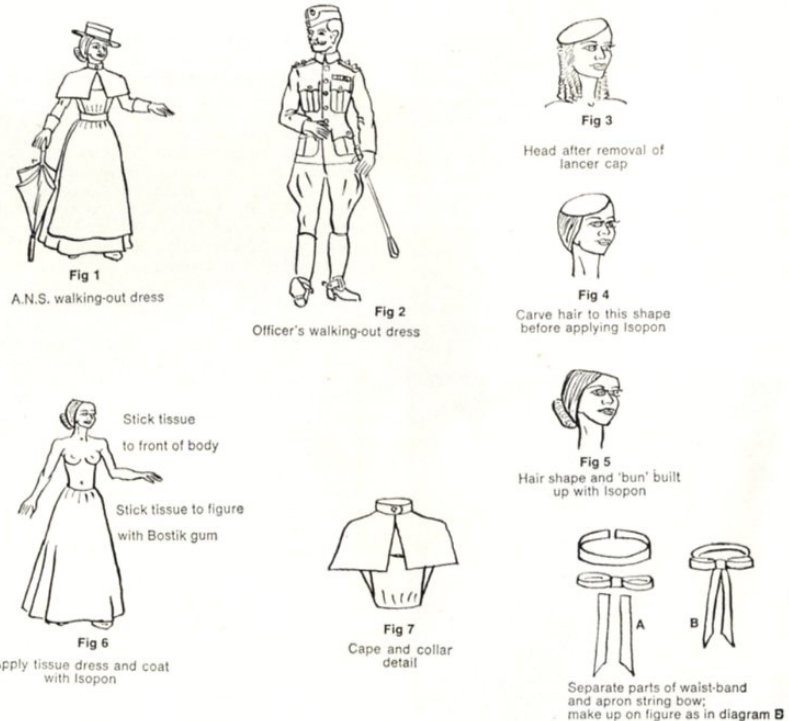

# Transport of 1914-1918

THESE THREE LORRIES OF THE FIRST WORLD WAR PERIOD WILL APPEAL TO BOTH MILITARY & PERIOD RAILWAY MODELLERS

By Gerald Scarborough

THE 1914-18 conflict was the first war in which the internal combustion engine was to prove a major factor, and in which trucks and cars were to play such a vital part. At the moment there appears to be only limited military interest in the World War 1 period on the part of the kit manufacturers (apart from the Airfix Mk I tank and 1914-18 soldier sets) and I hope this article will in part remedy that. I have been slowly collecting military vehicle information together and was finally spurred to action when I came across *Military Transport of World War 1* by Chris Ellis, published by Blandford in their 'Mechanised Warfare in Colour' series. At £1.25 it's worth saving your pocket money or fiddling the housekeeping allowance as the artwork by Dennis Bishop captures the styles of these vehicles admirably and Chris Ellis writes the interesting background to the types described.

To provide wargamers and military vehicle modellers with some suitable motor transport, I have produced ideas for scratch-building a couple of types of truck. I trust that readers will appreciate that detailed dimensions of vehicles of this period are extremely difficult to obtain and the actual vehicle types are in many cases still not in existence for direct measurement. The drawings given here, therefore, are based on the basic dimensions that were available and every care has been taken to endeavour to get the proportions correct. However, in this small 1:76 scale any errors will, I hope,

be very minute, and a satisfactory replica will result.

## VULCAN

The Vulcan Motor and Engineering Co (1806) Ltd, of Southport was taken over by Tilling-Stevens Ltd in 1939 and the whole lot have since been absorbed by the Rootes Group of Companies. The Vulcan factory had a reputation for durability, and there was a restored example of the type drawn still running in 1957 and probably still in existence today. The engine was a four cylinder unit of 22.4 HP (RAC) and drove through a four speed and reverse gearbox to a worm final drive. Wheels were solid rubber tyred, twin at the rear and the body was boarded over and covered with roof cloth.

The model is representative of the types that were 'called up' for active service for use as general transport and ambulances, etc. A few kit parts can be incorporated in the construction though the majority is of necessity scratch built. The wheels are perhaps the trickiest parts and for the front I used a pair of Airfix T-34 roadwheels left over from previous conversions. All that is required is to mark out and drill a circle of eight holes using a 1/32 inch drill and eight larger holes, say 3/64 inches, outside these. Cut away any plastic remaining between to leave the 'spokes' as shown on the drawing. The rear wheels have a very complicated 'cast' spoke and I didn't really consider cutting these out as feasible in

this scale. However, if you take a pair of Centurion road wheels (T-34s would do), it is possible to add these spokes from stretched sprue carefully cut to length and bent to shape. There were twin wheels at the rear but of course it is only necessary to 'spoke' the outers. The construction of the chassis should be clear from the sketch: build it upside down and make sure it sets square; then add the Microstrip springs on stretched sprue hangers. The body is made up with a bottom of 20 thou Plastikard, sides and end from 15 thou. The sides should be about 2 mm higher than shown on the plan with an overlay of 10 thou to the correct size. This will allow an overlap for fixing the tilt which is cut out and

**Heading:** The Berna model is based on this actual vehicle now preserved in Switzerland. **Below:** Sub-assemblies for the Vulcan model.

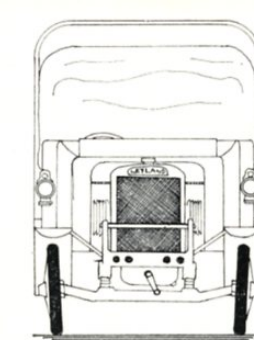
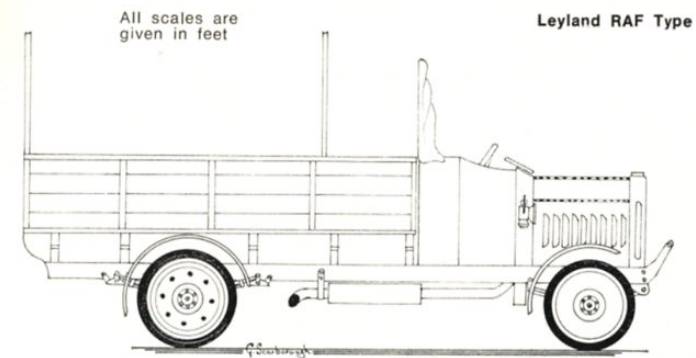
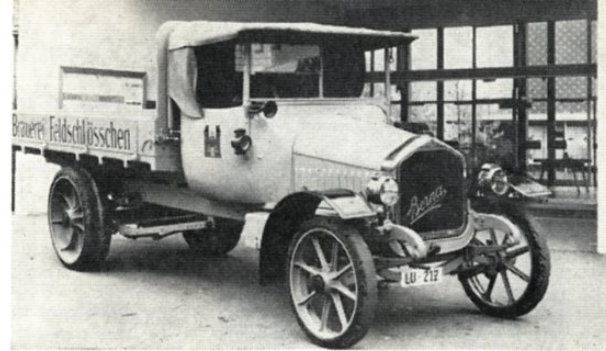
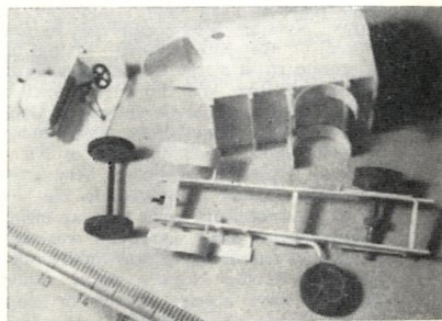

1:76 scale

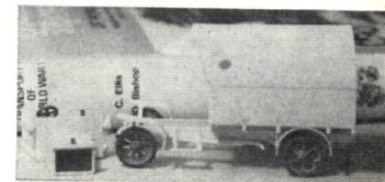
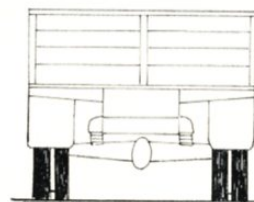
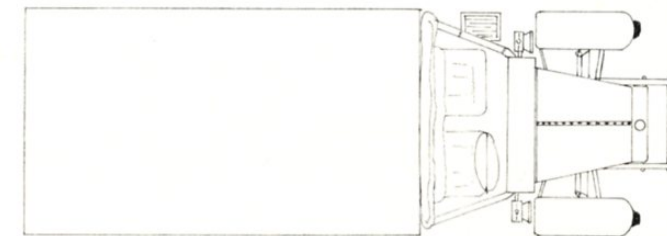

**Top:** Completed model of the Leyland lorry—this is equally suitable for old-time model railway scenes.

**Above:** The Vulcan model under assembly.

moulded round a dowel of 1/4 inch diameter, or as near as you can get to that, using the usual boiling water treatment. The driver's seat (from an Austin truck) and the front hood can be added. The inside is painted at this stage and the five body bearers added underneath.

The cab/bonnet section construction is also shown in the sketch but note the cab only has one side, the near side being left open. Include the gear and brake levers and the pedals if possible with a steering wheel from a Bren Gun Carrier or similar. The bonnet top is cut from an Austin Ambulance with sides of 20 thou Plastikard, the radiator a Microstrip frame with vertical 'tubes' cut from plastic rod.

After assembling the body and bonnet/cab units to the chassis, add the mudguards from 10 thou Plastikard, moulded round dowel and with stays from Microstrip. The curved portions of the front mudguards I moulded round the handle of a hot poker. The front axle is bent from plastic rod and the rear was from two Sherman tank guns, cut, stuck and filed to shape, or alternatively plastic rod could be used. Finally, add the smaller bits of detail like the lights, step, exhaust, starting handle, etc. There was a range of plastic Veteran Car kits being distributed recently by Jet Petrol stations and similar kits are marketed by Harbutts (see advert on page 210, January 1970 issue). These kits, although to odd scales, are extremely useful for lamps, steering wheels, starting handles, etc, so are well worth acquiring.

## LEYLAND

The Leyland 3 ton 'subsidiy' vehicles were used in the thousands by both the Army and the RFC/RAF, often being fitted with specialist bodywork, eg, workshop, fuel tankers, balloon vehicles, etc. They were extremely rugged vehicles and many survived the war to be re-purchased by Leylands, reconditioned, and resold

June, 1971

(with a two-year guarantee) to have various bodies built on them for commercial use. One particular example was purchased by Chivers and Sons Ltd of Cambridge in 1919, fitted with a box type body and used for delivery work in London until 1934 when it was retired for general work in their factory at Histon. It was then converted into a water carrier as part of the factory's fire brigade in the second world war, subsequently working on Chivers Farms until, in 1959, it was completely restored by them and later presented to the Historic Commercial Vehicle Club.

The truck version makes a relatively simple model, utilising Airfix Panther tank road wheels, convex at the front, backed with a disc of 10 thou Plastikard and twin concave (with the boss cut off) at the rear. Mould an outer rim from a 4 mm wide strip of 10 thou card and add the individual 'tyres' from Microstrip. The body, bonnet/cab and chassis

construction are all shown on the sketch (note door on left side only) and is basically similar to the Vulcan previously described. The front axle is from an Austin K6 and the rear cut from a Matador, but more or less anything similar will do. Springs are spares from Austins or built up from Microstrip, and the bench seat is from the Airfix German half-track.

## BERNA

The Berna C2 motor lorry from Olten, near Berne, Switzerland, produced by Moterwerke Berna AG, was manufactured until 1918, being supplied to both the Swiss and the Allied armies. Fifty chassis a month were produced, a large output for those days. An example of this vehicle, restored by the works apprentices, in the livery of the Feldschlosschen Brewery, can be seen in the Swiss Institute of Transport and Com-

Continued on next page

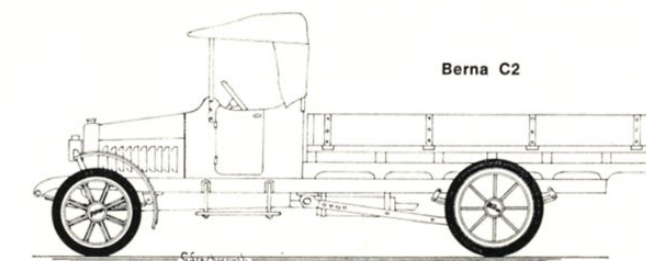

Berna C2

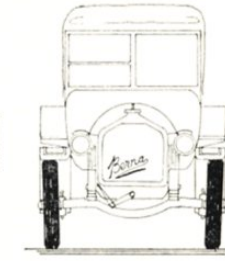

1:76 scale

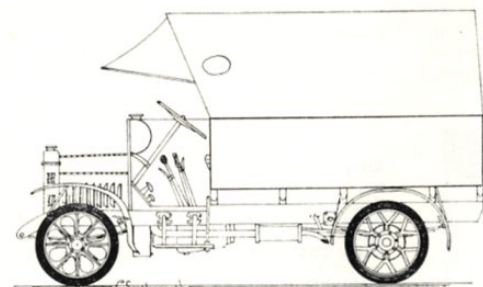
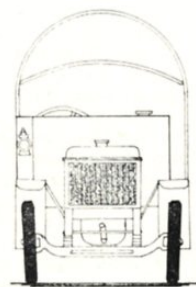
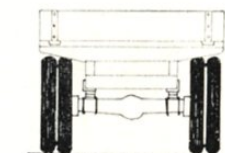
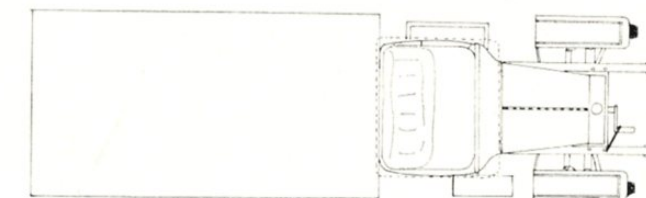

Tilt omitted in plan view

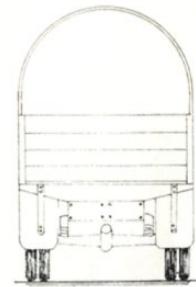

1:76 scale



Vulcan Lorry

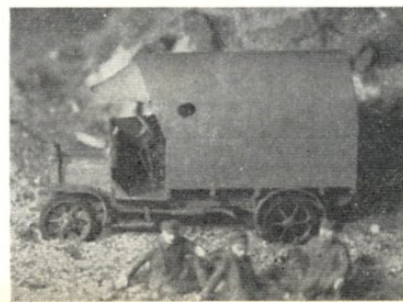

**Transport—continued**

munications Museum on the shores of Lake Lucerne, to the Curator of which I am indebted for information from which the drawings were produced. This museum is well worth a visit by any modeller lucky enough to be holidaying in that area for it has a fine display of model railways, aircraft and ships, as well as the collection of full-size exhibits.

For this model I used wheels from one of the previously mentioned 'free' Jet or Harbutt's kits, the 1904 Mercedes being the nearest for the front spoked wheels. The rear are scratch built with a rim moulded from 20 thou Plastikard strips, twin tyres from Microstrip, the centre from a disc of 20 thou Plastikard, a hub from an Airfix Quad and 'spokes' from more Microstrip. Note that these wheels

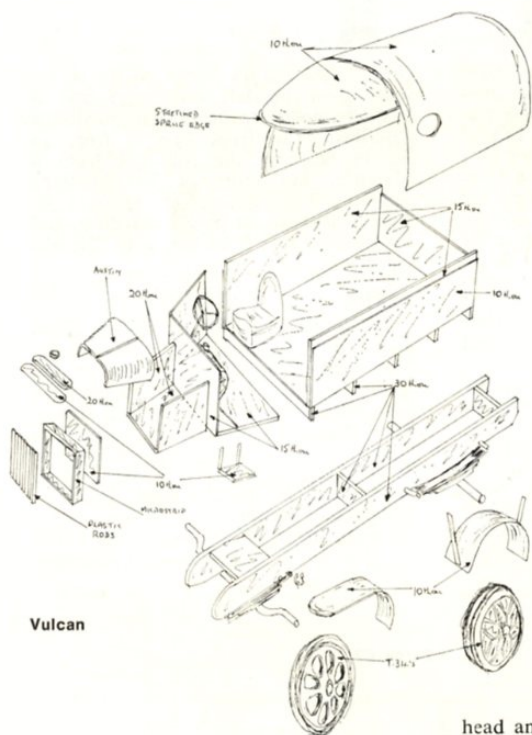

**Vulcan**

were a solid disc with strengthening spokes cast in and very deeply dished. The rear axle is cut from a K-M half-track front axle.

The body again is simple and shown in the sketch. Add the ironwork to the sides, bearers and separate chassis runners and set aside to dry. The cab section (again with a door on only the left side) is a very 'rounded' shape and thick Plastikard, or suitable laminations, are needed to give enough material to allow this shape to be produced. It is easier if first the driving compartment 'box' is shaped. Then add the partly shaped front bulk-

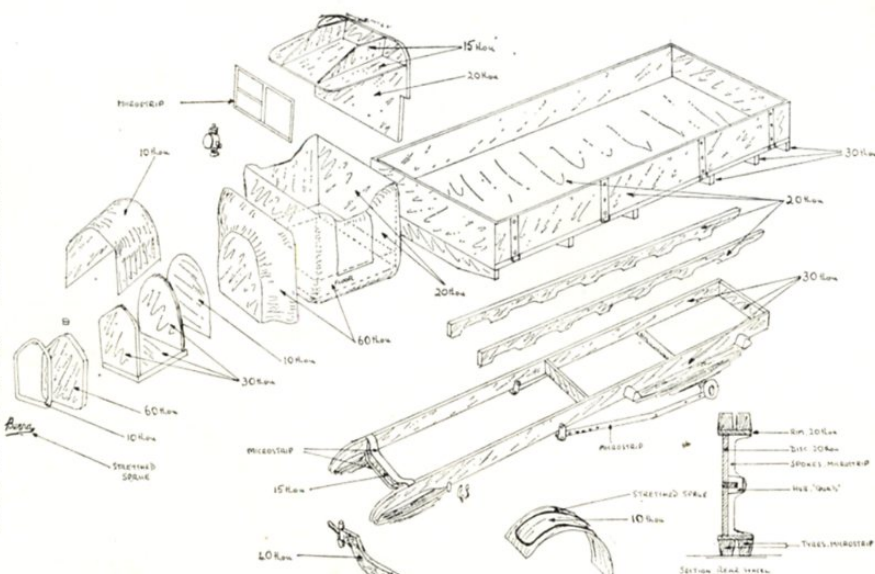

**Berna**  
constructional diagrams  
(not to scale)

head and finally the 10 thou face, giving a last sanding to shape when all is dry. The rest of the chassis and final assembly should be clear from the sketch and is essentially similar to the Leyland and Vulcan. The mudguards have a quite distinctive beading and this can be added from stretched sprue after they have been moulded. If you can manage the name Berna on the radiator this can also come from stretched sprue.

For anyone interested in wargames of the 1914-18 period, these models could, of course, be further simplified for speed of building. For example, the Vulcan would not look amiss with unmodified T-34 road wheels and a lot of the fragile detail could also be left off without

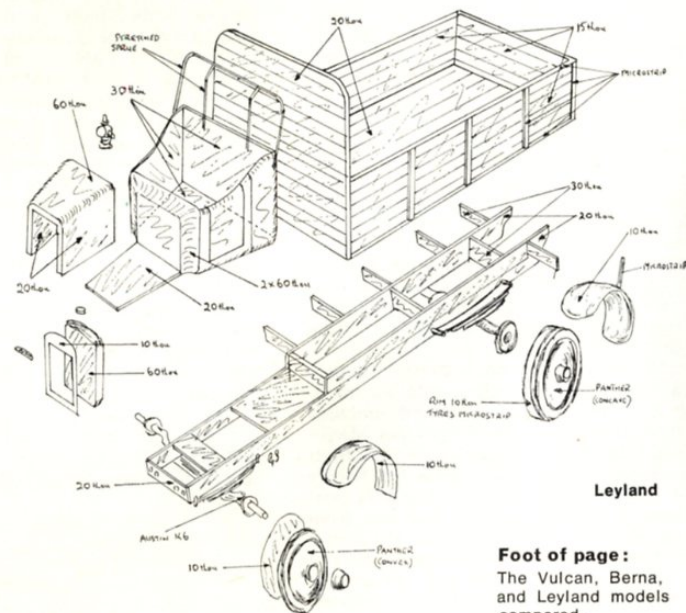

**Leyland**

**Foot of page:**  
The Vulcan, Berna, and Leyland models compared.

spoiling the effect. As for colour schemes, the Vulcan is in Humbrol Khaki, the Leyland in a mixture of British Desert Sand/Dark Green to give a lighter green similar to that in the artwork illustration in the Blandford book, and the Berna is basically in Medium Grey.



# Simple T-6G Harvard Variants

Only detail and colour scheme changes are needed to make a whole range of Harvards—an ideal project for beginners to kit converting.

By Alan W. Hall



A Canadian-built Harvard IV belonging to No 400 Squadron RCAF—an auxiliary squadron stationed at Downsview, Toronto. Painted overall yellow, the cowling stripes are red and white. Codes and serials (in this case 3125 on the fin) are in black. The squadron crest, which consists of a Griffon's head in red surmounting two gold-coloured tomahawks, appears under the front cockpit (Doug Baker).

THIS month's conversion is a simple one. The Airfix kit of the North American T-6 Harvard is an accurate representation of the real thing and although there is only one complicated conversion that one can make from it—that of the earlier Harvard I in RAF service—it's use throughout the world has led to a number of minor changes in external appearance.

I have concentrated on the LT-6G which was used in Korea for air observation post duties and spotting for the 'heavy artillery' bomber force by laying target marking rockets. Apart from the armament and various extra aerals, the LT-6G is basically similar to the T-6G trainer. This varied from its predecessors by having a spinner, radio mast behind the cockpit, D/F fairing and less framing on the canopy. Airmodel have recently issued a modified cockpit canopy for the T-6G and with this advantage I was able to complete the conversion in a relatively short time. This is an ideal project, therefore, for a beginner, or for more experienced modellers who may not previously have tried kit converting.



Following the completion of the construction work the Airmodel canopy has been cut from its PVC sheet and shaped to fit. The framework has been painted before assembly. A radio aerial and D/F fairing have also been made. In this view the canopy and areas which will appear in black on the finished model have been painted and masked before the application of silver. Note the new propeller and spinner on the left.

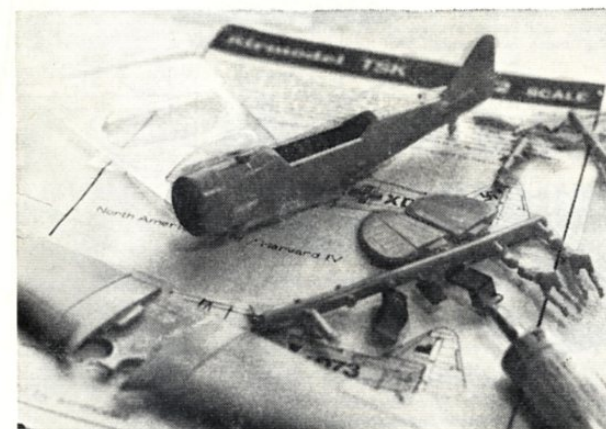

The fuselage and engine cowling parts are glued together and the wing halves joined in accordance with kit instructions. Wheels and seats are painted black and set aside to dry. Note that the locating hole for the radio mast, forward of the cockpit, has been filled with body putty.

and then found that various types of file were the best way in which to get the shape accurate. The work may take a little time but the canopy is a good, exceptionally clear one and if the guide lines are followed fits perfectly.

**STAGE 3** Before putting the canopy in place I painted the framing silver. This is often easier than doing the job when the model is fully assembled as the wings tend to get in the way. Mistakes at this stage can often be rectified rather than when on the model. I also made the new spinner, radio mast and D/F fairing at this time. The former came from a piece of dowel shaped and then cut to size. The prop blades came from the kit but note that the T-6G had squared off propeller tips. Small holes were drilled in the spinner to take the blades. The aerial came from the kit mast cut down and the D/F loop was made from a small piece of scrap sprue.

**STAGE 4** Before putting the undercarriage on I made the underwing rocket launchers. The plans will show the shape of these which were made from Plastikard and scrap sprue. Rockets came from either the Gnat or Hunter kits. They are too long in their kit form and I had to cut them down, about 1/4 in. from the tail fins and glue these back on again. The undercarriage legs were then assembled together with the tailwheel. Main wheels were put on last of all after painting had been completed.

**STAGE 1** The kit is assembled according to the instructions in the packet in as far as the fuselage, wings and tail unit are concerned. Body putty is used to fill the location hole for the radio mast forward of the cockpit and, if required, the stand slot under the fuselage. The fuselage interior was painted in chromate green before assembly and the cockpit divider and seats black. The wheels were also painted at this stage whilst black was being used.

**STAGE 2** The Airmodel canopy was then fitted. This series, produced in Germany and marketed by Argyle Models and other leading shops in the UK, uses clear PVC for the mouldings. The result is an exceptionally tough canopy which will need a lot of careful work to fit to the fuselage contours as it is liable to split unless care is taken. I used a sharp knife to remove it from the base sheet

**STAGE 5** Painting can now begin and here I preferred to paint the black anti-dazzle panel and red tip to the fin and rudder before the silver, masking the other colours out so that I did not have to worry about getting a clean edge when

Continued on page 532; scale drawings on next page

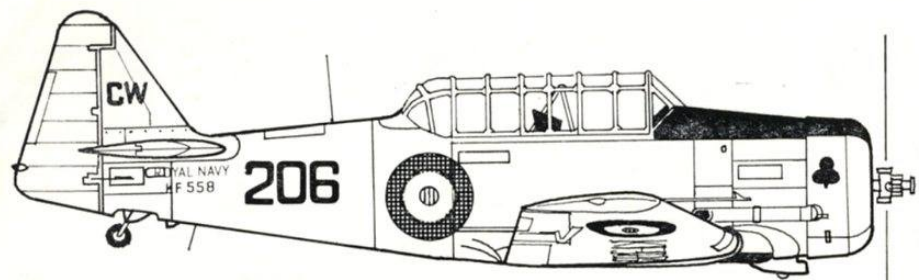

North American Harvard II KF558 '260' Royal Navy  
Natural metal overall and black codes and serial

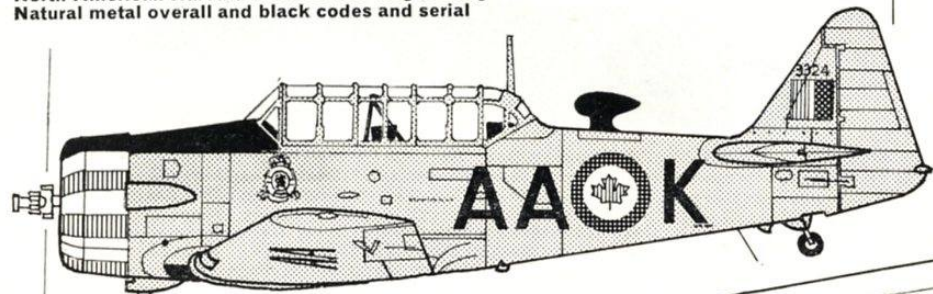

North American Harvard IV No 400 Sqn Downsville  
Toronto. Serial on fin is 3324. Red and white bands  
on cowling.

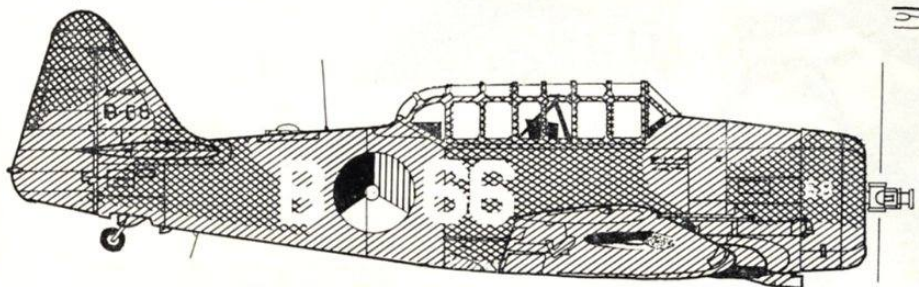
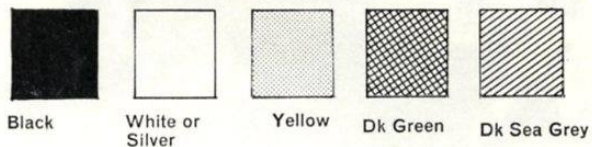

North American Harvard II  
Royal Netherlands Air Force. Dk Green/Sea Grey overall. All codes and  
stencilled lettering in white. Fin serial reads: 43-00266 followed by B-66.

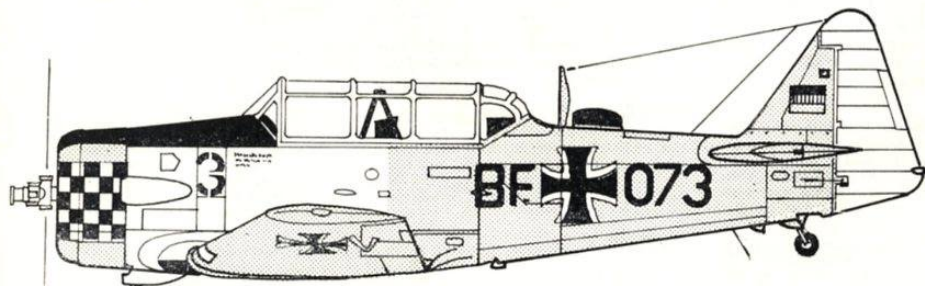

North American T-6 Harvard IV Luftwaffe stationed at  
Kaufbeuren Fliegerhorst TSLW 1 South Germany.  
Yellow overall apart from dayglow forward fuselage and  
rudder. Black and white checks on cowling. Code '3' in blue  
All other codes in black

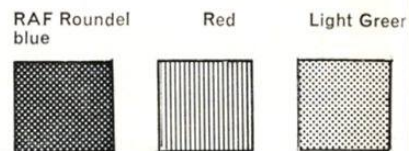

Drawings by Alan W. Hall

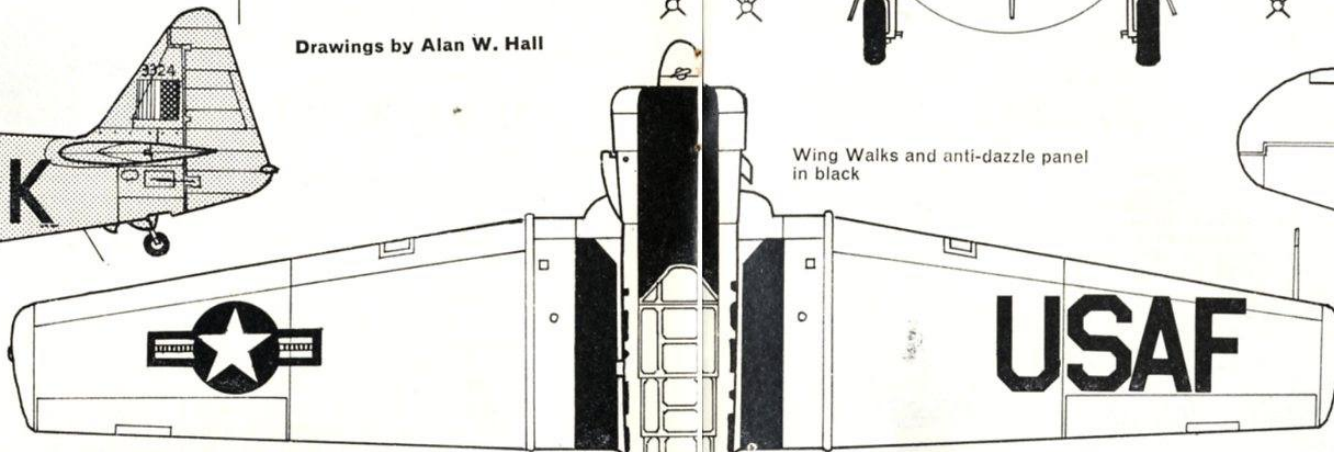

Wing Walks and anti-dazzle panel  
in black

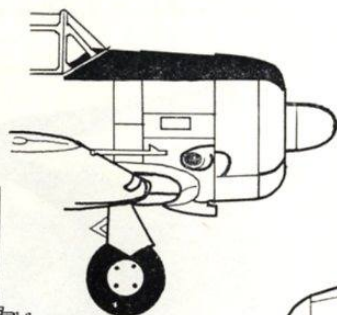

Right hand side  
view of 93584  
shows short exhaust  
port

Article continues on the other  
side of the advertising section; unstaple  
centre pages to work from drawing.

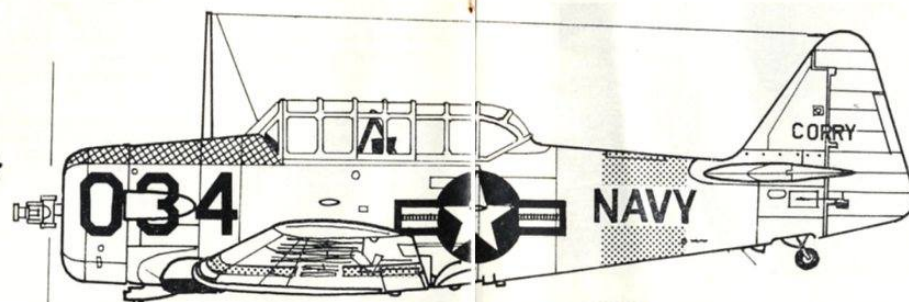

North American SNJ-3 Harvard. Stationed at NAS Corry 1952.  
Overall natural metal. Codes in black. Light Green band on rear fuselage  
and upper and lower wing surfaces. Starboard upper wing has '034' breaking  
green band followed by 'CORRY'. Lower wing surfaces have (Starboard) 'CORRY'  
and (port) '034' and 'NAVY'

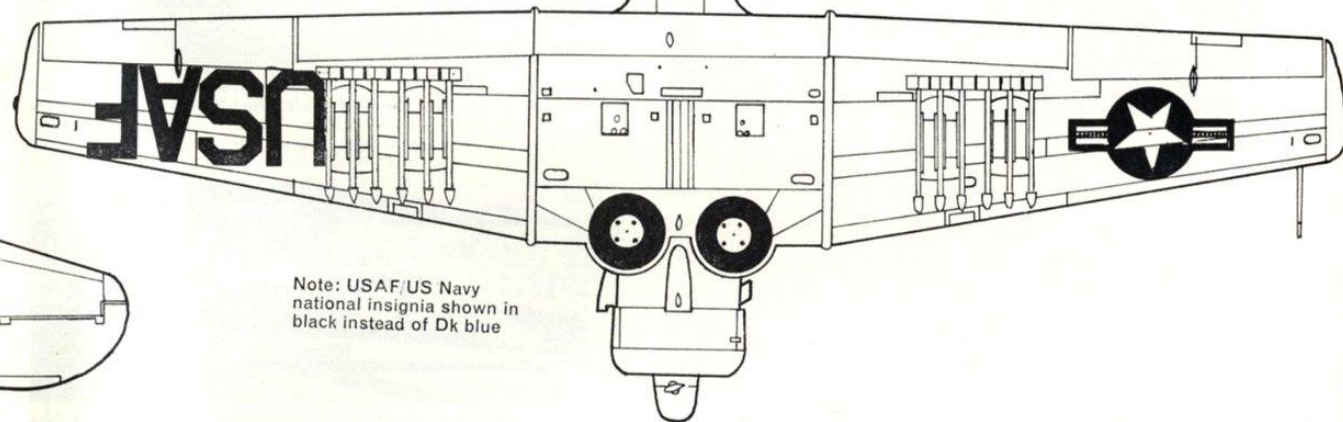
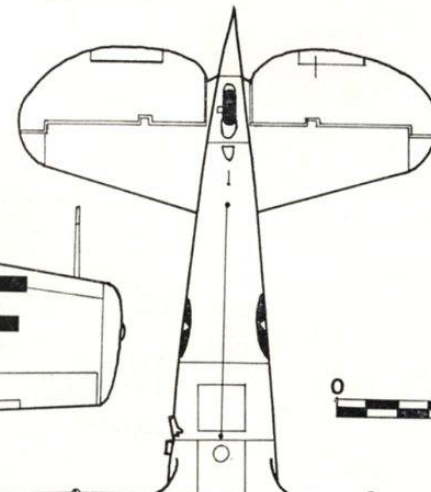
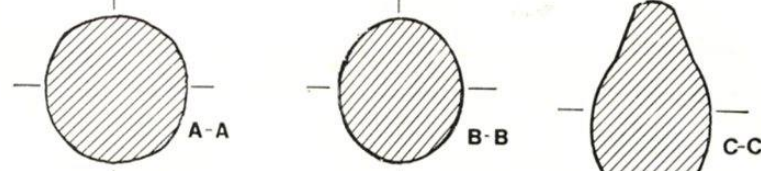
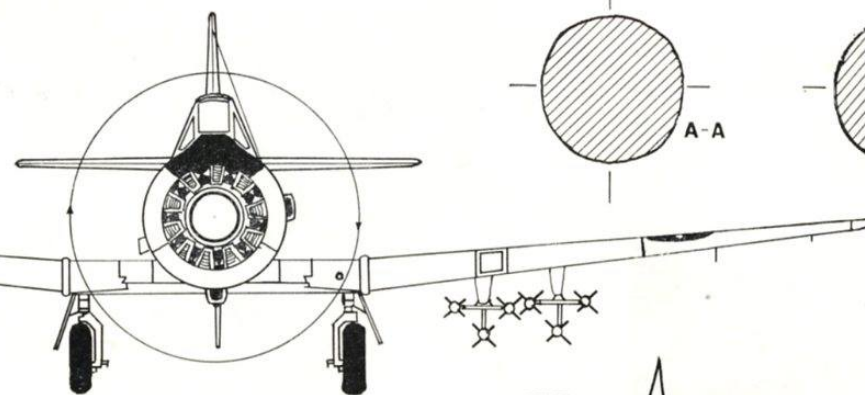

Note: USAF/US Navy  
national insignia shown in  
black instead of Dk blue

North American LT-6G. '93584'. 6147th Tactical Control Group Korea 1952.  
Aircraft natural metal overall. Red tip to rudder. Codes and serial in black

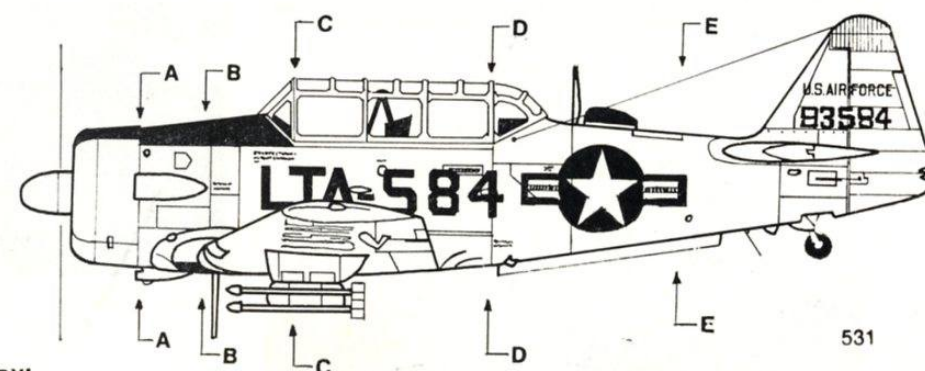

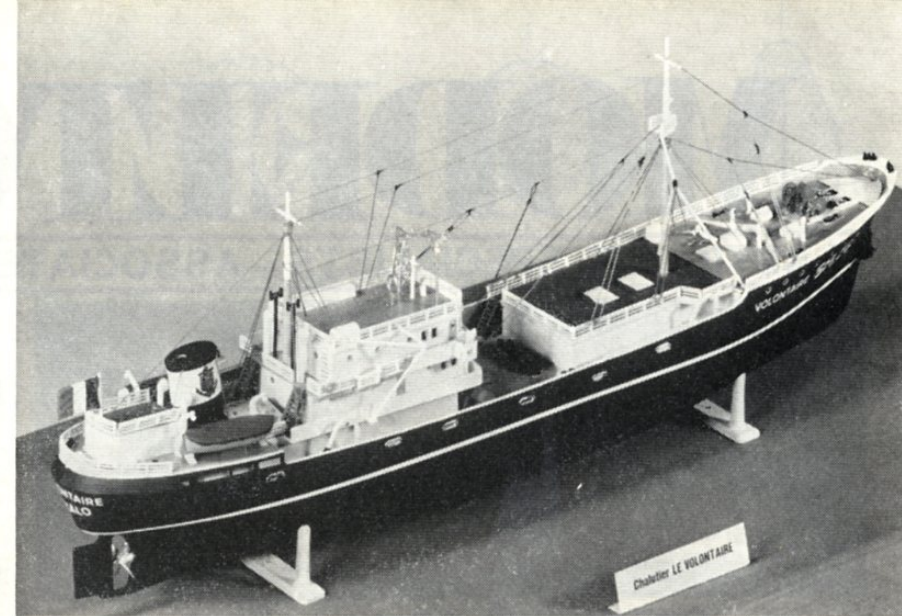
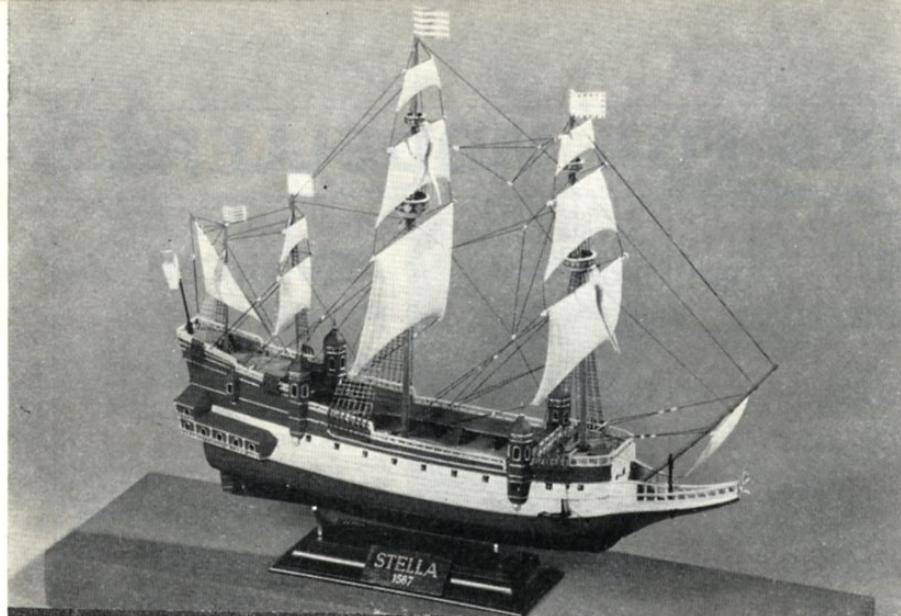

Advertisement Feature

# Heller

Heller's range of kits, just comprehensively introduced into the British market and distributed by RIKO, are available now from all good Hobby Shops. The kits are well moulded, beautifully detailed and inexpensively priced. They deserve a good, close look by all modellers interested in aircraft, cars and modern and old ships. Write to Richard Kohnstam Ltd., 13-15A, High Street, Hemel Hempstead, Herts, enclosing 10p for 38-page fully coloured catalogue and price list. On these pages we show just 8 out of Heller's range of over 120 kits.

*Top left.* The 1/200th scale STELLA, produced by Heller from drawings of Van Stok of Rotterdam. This ship is reputed to have been part of Phillip II of Spain's invincible Armada.

*Top centre.* Heller's 1/100th scale model of the famous polar exploration ship POURQUOI-PAS? It was used between 1908 and 1936 in both the Arctic and Antarctic regions.

*Top right.* Heller's LE VOLONTAIRE in 1/200th scale was

moulded from plans supplied by the shipyard which made this real deep sea trawler and which sails from St. Malo.

*Right.* The Naval version of the Jaguar, modified for operation from aircraft carriers. Heller also makes two other versions of this new Anglo/French Fighter, all in 1/50th scale.

*Below right:* Heller's 1/50th scale Mystere 20 twin jet executive aircraft made by Dassault. The model has retractable undercarriage and is one of many interesting civil aircraft models in Heller's range.

*Below centre.* The Leo 451, one of Heller's outstanding 1/72nd Museum series of rare historic aircraft. This aircraft is an outstanding addition to any 1/72nd scale aircraft collection.

*Below left.* The 22,000 ton light attack carrier CLEMENCEAU reproduced by Heller in 1/400th scale.

*Left.* The outstanding Renault 16. The only car in Heller's kit range in 1/20th scale with opening doors, interior detail—even a place for the car radio. Plans approved by Renault.

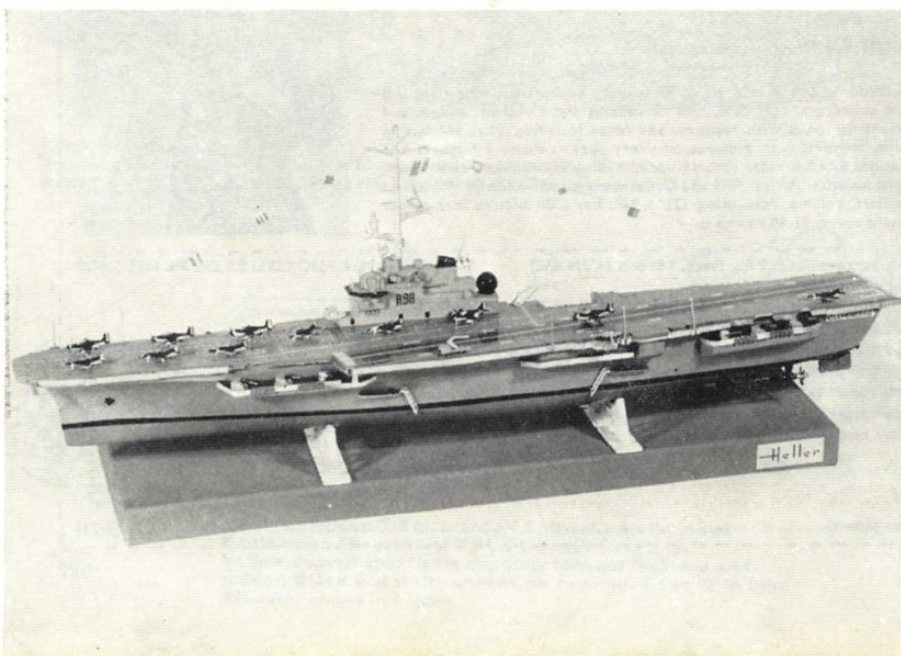
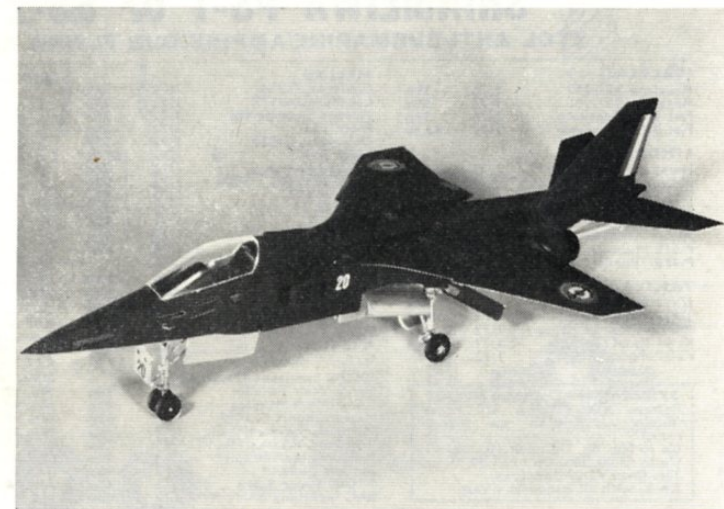



# MODELTOYS

PLASTIC KIT SPECIALISTS—ASSOCIATE MEMBER I.P.M.S.



This latest addition to the Hasegawa 1/72 range, is treated in their usual manner, with fine attention to detail. A truly impressive model. price £3.75

- Also available:
- |                                 |      |       |
|---------------------------------|------|-------|
| Lockheed T-33A Shooting Star    | 1/72 | 34p   |
| Curtiss SOC-3 Seagull Landplane | 1/72 | 34p   |
| T-38A/(F-5B) Talon              | 1/72 | 34p   |
| F-86F Sabre                     | 1/72 | 34p   |
| Heinkel HE.51A-1 Landplane      | 1/72 | 44p   |
| Heinkel HE.51B-2 Floatplane     | 1/72 | 63p   |
| C. Seagull Floatplane           | 1/72 | 63p   |
| Cessna A-37A                    | 1/72 | 63p   |
| Type 94-I "All" Floatplane      | 1/72 | 75p   |
| Mitsubishi "Betty"              | 1/72 | £1.44 |
| F-106A Delta Dart               | 1/72 | 90p   |
| H6K5 Mavis Flying Boat          | 1/72 | £3.14 |

## SHINMEIWA PS-1 or SS-2

STOL ANTI-SUBMARINE/AMPHIBIOUS FLYING BOAT

- |                       |      |       |
|-----------------------|------|-------|
| <b>ITALAEREI</b>      |      |       |
| Reggiane RE-2000      | 1/72 | 59p   |
| Reggiane RE-2001      | 1/72 | 59p   |
| Fiat G-55 Centauro    | 1/72 | 59p   |
| Fiat BR.20 Cicogna    | 1/72 | £1.35 |
| <b>LINDBERG</b>       |      |       |
| Heinkel H.E.162       | 1/72 | 30p   |
| Messerschmitt M.E.163 | 1/72 | 30p   |
| Focke-Wulf F.W.190D-9 | 1/72 | 30p   |
| Heinkel HE.100        | 1/72 | 30p   |
| Dornier DO-335A       | 1/72 | 45p   |
| Arado AR.234B 'Blitz' | 1/72 | 45p   |
| P-51B Mustang         | 1/72 | 45p   |
| P-47B Thunderbolt     | 1/72 | 45p   |
| <b>TAMIYA</b>         |      |       |
| J7W1 Shinden canard   | 1/72 | 30p   |
| J2M3 Raiden (Jack)    | 1/72 | 30p   |
| A6M3 Model 32 Hamp    | 1/72 | 30p   |
| Ki 44 Shoki (Tojo)    | 1/72 | 30p   |
| Ki-84 Hayate (Frank)  | 1/72 | 30p   |

- |                                    |      |       |
|------------------------------------|------|-------|
| <b>HELLER</b>                      |      |       |
| Cauldron C-714                     | 1/72 | 25p   |
| Les Mureaux 117                    | 1/72 | 25p   |
| Marone Saulnier 406                | 1/72 | 25p   |
| Bloch 152                          | 1/72 | 25p   |
| Dewoitine D-520                    | 1/72 | 25p   |
| Bloch 210                          | 1/72 | £1.25 |
| Amiot 143                          | 1/72 | 92p   |
| Bloch 174                          | 1/72 | 92p   |
| Breguet 693                        | 1/72 | 92p   |
| Potez 63-11                        | 1/72 | 92p   |
| Potez 631                          | 1/72 | 92p   |
| Leo 451                            | 1/72 | 92p   |
| Liore et Olivier 45                | 1/72 | 92p   |
| <b>FUJIMI</b>                      |      |       |
| F4E Phantom                        | 1/48 | £2.90 |
| A.6A Intruder                      | 1/48 | £2.25 |
| D. Mirage 111c                     | 1/48 | £1.13 |
| D. Mirage 111R                     | 1/48 | £1.20 |
| TA-4F Skyhawk                      | 1/48 | 93p   |
| A.4E Skyhawk                       | 1/48 | 93p   |
| G. E.-2A Hawkeye                   | 1/72 | £1.63 |
| <b>FRIG</b> *re-issued, new decals |      |       |
| Focke-Wulf TA152H                  | 1/72 | 19p   |
| P-51A/Mk.II Mustang                | 1/72 | 19p   |
| Messerschmitt BF.109F              | 1/72 | 26p   |
| Fairey Barracuda II*               | 1/72 | 26p   |
| Westland Wessex Mk.1*              | 1/72 | 26p   |
| B. Beaufighter Mk. 21*             | 1/72 | 36p   |
| Junkers Ju-88A*                    | 1/72 | 36p   |
| F-100D Super Sabre                 | 1/72 | 45p   |
| BAC Lightning 6                    | 1/72 | 45p   |

BY RETURN POSTAL SERVICE  
Postage and Packing, UK rates  
(Books and Decals see special rates)  
Up to 50p, 8p. Up to £1.10, 12p  
Up to £3.00, 25p. Up to £5.00, 30p. Over £5.00 Post Free.  
S.A.E. with all enquiries please.

- AIRCAM AVIATION BOOKS**  
£1.05 each Postage 8p each
- North American P-51D Mustang
  - P-47 Thunderbolt
  - Mustangs Mk.I-IV
  - Merlin engined Spitfires
  - PS1B Mustang in USAAF service
  - P-40 I-IV Kittyhawk
  - P-40-N Warhawk
  - Griffon engined Spitfires Mk.s. XII-24
  - Spad VII and XIII Scouts
  - P-38 Lightning
  - B-24 Liberator
  - Avro Lancaster
  - Nakajima Ki-43, Hayabusa I-III
- MEN AND MACHINES AVIATION BOOKS.** £1.75, postage 15p each
- Luftwaffe Bombers WWII Vol. 1
  - RAF Bombers WWII Vol. 1
  - Japanese Bombers WWII Vol. 1
  - American Fighters WWII Vol. 1
  - RAF Fighters WWII Vol. 2
  - NEW MICRO-SCALE DECALS 1/72 SCALE 75p each
  - No. 67 Japanese Aces WWII personal markings
  - No. 68 Japanese Group Markings No. 1 Tail Emblems
  - No. 69 Japanese Group Markings No. 2 Tail Emblems
  - No. 70 Japanese Group Markings No. 3 Tail Emblems
  - DE-FREY DECALS 1/72 SCALE
  - RAF Bomber Command Dull Red Codes 1/72 20p
  - RAF Black and White Invasion Stripes 1/72 and 1/48 25p
  - AUTHENTICAL DECALS 1/72
  - No. 6 U.S. National Insignia, pre-war and all WWII styles price 75p

Sheet No. 9, United States Navy  
D.A-IJ Skyraider, VA-176 U.S.S. Intrepid 1968  
L.T.V. A-7E Corsair, VA-195 U.S.S. Kittyhawk 1970  
S.SH-3A Sea King, HS-3, U.S.S. Randolph circa 1967 Illustrated below.



MODELDECAL—THE FINEST! JUDGE FOR YOURSELF.  
AVAILABLE ONLY FROM MODELTOYS

## MODELDECAL DECALS 1/72

- No. 1 Six alternative finishes for the BAC Lightning in RAF service
  - No. 2 Three alternative finishes for the McDonnell Phantom
  - No. 3 Four alternative USAF finishes for the F-100D Super Sabre
  - No. 4 WWII US Navy set. Hellcat, Dauntless and Avenger
  - No. 5 Luftwaffe WWII set. FW 190D-9, Storch, Dornier Do217E-4
  - No. 6 WWII US Navy set. Corsair, Helldiver, Kingfisher
  - No. 7 RAF Hunter F-6, Phantom FGR-2, Harrier GR-1, Meteor F-4
  - No. 8 USAF Tail Codes, Serials, Insignia and General Markings
- \*MODELDECAL\* style fully illustrated instruction sheet, giving decal locations and full colour scheme details, is included with all Modeldecals.

<b>PRICES</b>	
Modeldecals Nos. 1, 3, 8, 9	38p
Modeldecals No. 7	33p
Modeldecals Nos. 2, 4, 5, 6	28p
Postage on all decals: up to 3 sheets 5p, 4 and over 8p UK.	

**NOTE:** All Modeldecals sheets contain full markings to complete all models listed except sheets Nos. 1, 2 and 7, where the 'D' type roundels are used from the respective kits. However, the Hunter section only on No. 7 does include roundels. Harrier markings on No. 7 are intended to complement those in the Frog kit. Instrument panels included for all machines on sheets Nos. 3, 7, 9.

**OVERSEAS TRADERS:** These superb decals are already stocked by traders in many countries, immediate supplies available with full terms. Details on request.

**WRITE, PHONE OR CALL IN Shop Hours 09.30-12.30, 13.30-17.30 Mon.- Sat. Closed Weds.**

# 246 Kingston Rd Portsmouth

Tel • Portsmouth 61469

# PSL BOOKS FOR MODELLERS

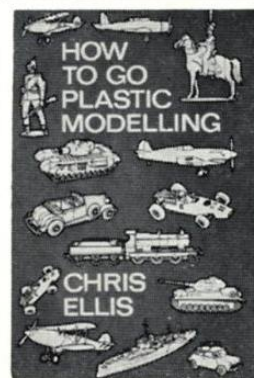

## HOW TO GO PLASTIC MODELLING

By Chris Ellis

Editor of AIRFIX Magazine

The second edition of an essential and comprehensive guide to plastic modelling. Ten chapters covering such topics as: basic assembly, detailing, converting, modelling, materials, tools, painting, transfers, markings, research, display, maintenance and scenic settings. 168 pages, 8 1/2" x 5 1/2", 80,000 words, 80 pictures, 7 pages of scale drawings, numerous sketches in the text. £1.50 net



## HOW TO GO ADVANCED PLASTIC MODELLING

Edited by Chris Ellis

Editor of AIRFIX Magazine

This invaluable book is the long-awaited companion volume to Chris Ellis' popular book for beginners. Sure to be enjoyed by thousands of modellers all over the world. Goes deeply into assembly, construction and conversion of many different types of plastic models. 192 pages, 8 1/2" x 5 1/2", 100 pictures, 68 drawings. £2.00 net

## fighting colours

RAF fighter camouflage and markings, 1937-1969

By Michael J. F. Bowyer



Michael J. F. Bowyer, well-known contributor to 'Airfix Magazine', details the development and changes in camouflage and markings of all Royal Air Force fighter types from 1937-1969, and lists the serial number allocations of every RAF fighter ever flown in that period. He records comprehensively how RAF colours altered over the years, against the background of contemporary events. Each chapter is illustrated with detailed line drawings, depicting specific aircraft in typical markings of the period, with 139 individual drawings in all. In addition to 157 excellent photographs, there are exhaustive appendices giving precise data on all RAF fighter types from 1937-1969. 192 pages, 8 1/2" x 5 1/2", case bound. £1.75 net

## HOW TO GO COLLECTING MODEL SOLDIERS

By Henry Harris

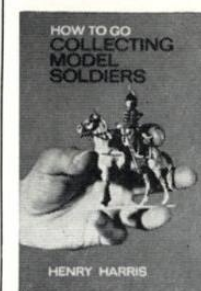

The definitive work, by an acknowledged military expert, on how to make the most of your collection. This, the third in the popular 'How To Go' series of books, covers choice of scales, displaying models, developing 'themes', and conversion ideas as well as surveying the history of the different arms. Gives advice on how to plan a model army from first principles and how to amass the men and materials for a serious collection. There are more than 70 superb photographs and an interesting chapter on wargames by Donald Featherstone. As well as a foreword by Brigadier Peter Young, there are eight instructive and fact-packed appendices featuring lists of manufacturers, societies, abbreviations and museums. This helpful book will appeal to all model soldier enthusiasts—both novices and experts. 200 pages, 8 1/2" x 5 1/2", case bound. £2.00 net

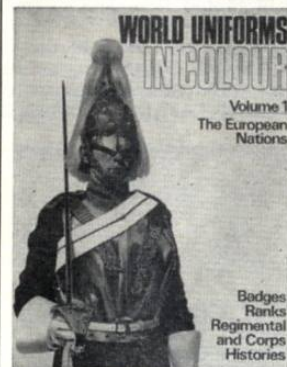

## WORLD UNIFORMS IN COLOUR

Two volumes

Two superb colour books of interest to all military enthusiasts, modellers and model soldier collectors, describing and illustrating the uniforms, badges and ranks of present-day units with regiment and corps histories. They are factual and detailed in content, with pictures on every page. Volume 1 features the European Nations and has more than 190 colour illustrations. Volume 2 covers 44 countries in America, Africa, Asia and Oceania and contains nearly 300 colour illustrations. Each volume, measuring 12 1/2" x 9 1/2", has a distinctive four-colour laminated board cover. £1.50 net each

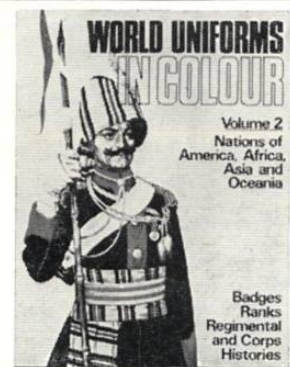

## How to order

To: Patrick Stephens Ltd, 9 Ely Place, London EC1N 6SQ OR: YOUR BOOKSELLER OR MODEL SHOP

- Please supply me with:
- .....copy/copies How To Go Plastic Modelling @ £1.50 net, plus 13p p & p
  - .....copy/copies How To Go Advanced Plastic Modelling @ £2.00 net, plus 13p p & p
  - .....copy/copies Fighting Colours @ £1.75 net, plus 13p p & p
  - .....copy/copies How To Go Collecting Model Soldiers @ £2.00 net, plus 13p p & p
  - .....copy/copies World Uniforms in Colour, Volume 1 @ £1.50 net, plus 25p p & p
  - .....copy/copies World Uniforms in Colour, Volume 2 @ £1.50 net, plus 25p p & p
- I enclose my remittance of £..... (including postage and packing) TOTAL £

NAME .....

ADDRESS .....

(Block caps please) ..... (6/71)

## Harvard Variants—continued

applying the silver. The canopy which had been stuck in place by this time and the wing walk-ways were also masked. I found all the markings I needed in the very useful AIR decals sheets of American markings. These can be obtained from Modeltoys of Portsmouth if required. Most experienced model makers will, however, have sufficient in their spare decals box to find the necessary marking detail for this model.

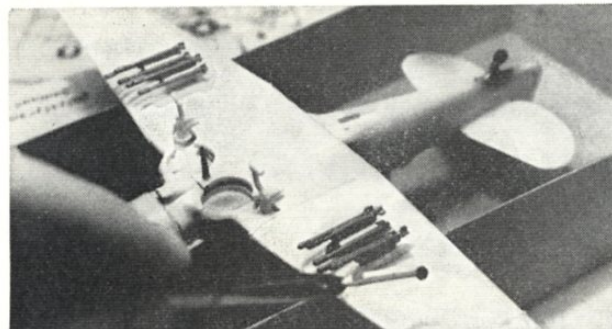

Above: Completed model of the LT-6G which was flown by the 6147th Tactical Control Group, Korea, 1952.

Left: Fitting the rockets on their mountings. These were from either the Hunter or Gnat kit offerings and cut down in length. Rocket launchers were made from spruce and Plastikard.

The Harvard offers a wealth of alternative colour schemes, both simple and complicated. The drawings (previous page) show some examples, and here are others shown in pictures.



A Harvard of the Royal Netherlands Air Force. Painted overall trainer yellow, this aircraft has a dayglo cowling, rear fuselage band and wing tips. Codes and serials, B-45, appear on the fuselage sides, cowling and fin in black. Note that the roundel appears on the starboard lower wing only.



An AT-6 Harvard used by the RAF for post-war training with the Rhodesian Air Training Group, RAF Thornhill. Serialled EX832, it was left natural metal overall with 'C' type roundels on the fuselage sides and 'B' above the wings.

Below: An AT-6A of the French Aeronavale serialled 84871 (Aviation Photo News).

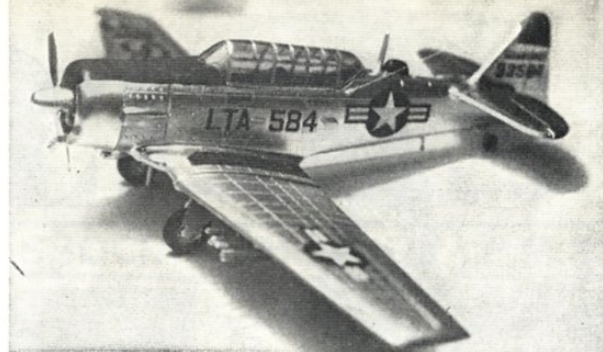

**STAGE 6** Final detailing includes sticking the wheels and undercarriage fairings in place and adding aerials. Two of the latter are involved, one from the top of the fin to the fuselage side and another under the fuselage. Small pieces of spruce were stuck in place before painting and then a very finely stretched piece of the same material was made by heating the plastic before pulling it out. Dividers showed the precise length of spruce needed. This was cut from the length and after two tiny drops of cement were placed at each end, gently put in place with tweezers.



Harvard 7559 of the South African Air Force. Rear fuselage and parts of the wings were painted in dayglo (Aviation Photo News).



NZ1078, a Harvard II of the Royal New Zealand Air Force. The cowling chequers appear to be red and white (Aviation Photo News).

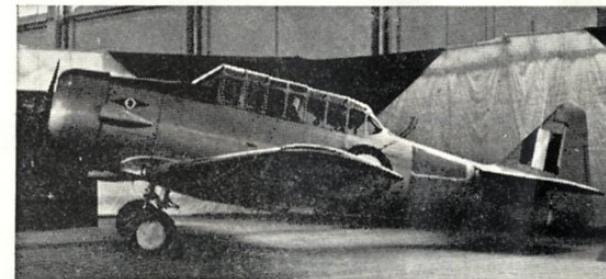

Harvard II FS890 seen at Little Rissington in CFS colours.

AIRFIX magazine

# BOOKS for modellers

Unless otherwise stated, books reviewed are normally available from your local bookshop or from hobby shops which sell books for enthusiasts, including the mail order stockists advertising in this magazine. As a last resort they can be obtained from the publishers whose addresses are given when known. In all cases of mail order, however, suitable postage should be added to the selling prices quoted.

## MARITIME

**Weyer's Warships (1971 edition).** *United States Naval Institute, published in UK by Patrick Stephens Ltd, 9 Ely Place, London EC1. £10.80.*

UNDER its original German title, *Taschenbuche de Flotte*, this famous publication has long been regarded as the German 'Jane' in that it provides an up-to-date and highly detailed record of the world's navies and their ships. Until recently it was produced only in Germany but now there is an English language edition which should greatly extend the book's appeal. Unlike 'Jane', this is produced as a pocket or hand book to the normal octavo format (or very nearly so), and it's both thick and glossy with a very durable flexible plastic binding in the best German fashion. The very neat little drawings must run literally to thousands, portraying each ship or class of ship nation by nation. A further section illustrates each ship or class yet again with pictures, and all essential data is given in easy-to-read form, much of it coded rather like a Michelin hotel guide, but using little gun, helicopter, and missile symbols, etc, rather than knives and forks. As an example of squeezing the proverbial quart into a pint pot this book is hard to beat. Aside from the ships there is extensive data on harbours, organisation, and so on. So while the price appears high, both the quality and quantity is commensurate for a very detailed reference book of this type.

## The Great Age of Sail.

*Edita SA, Lausanne. Published in UK by Patrick Stephens Ltd, 9 Ely Place, London EC1. £4.80.*

FIRST published in 1967, this lavish and beautifully produced book now appears in a second edition at less than half its original price. The new edition differs from the original, however, in having a slightly smaller page size. The many colour plates are now directly printed on the page, while in the first edition they were added by hand as separate plates, which largely accounted for its original high 'connoisseur' price. Basically this book takes a number of famous ships ranging from the *Santa Maria* through to the great barque *Pamir*, most highly developed of sailing ships, and treats each vessel in monograph form with extensive picture coverage. Each section is contributed by a noted authority on the subject and the illustrations come from many sources. So the book is a major treat for lovers of sailing ships and ship modellers will find the many drawings and detail views most

useful for reference and as a source of ideas.

**Warship Profile 5: HMS 'Campbeltown'.** *John Wingate. Profile Publications Ltd, Coburg House, Sheet Street, Windsor, Berks. 50p.*

THIS title in the Warship Profile series will be a 'must' for anyone making the Airfix kit of this famous ship. The pictorial coverage is most complete and will enable anyone who wishes to convert the kit (or Revell's larger scale model) to make a very accurate job of it. In fact it would be possible to make at least three models depicting the vessel at various stages of her career. The well-written and highly detailed text complements the excellent illustrations. Highly commended.

## MILITARY

**Uniforms of Marlborough's Wars.** *Lt-Col Frank Wilson and Arthur Kipling. Charles Knight & Co Ltd, 11-12 Bury Street, London EC3. £1.25.*

THIS book should be of value to those painting up miniature figures of the Marlburian period since it includes eight colour paintings of British and French troops (with detail views in some cases, too), and these are supplemented by line drawings showing other figures, some uniform details, and weapons. The drawings are augmented by descriptive text which in some cases is a little on the brief side. The publishers do not claim the book to be any more than a guide to assist wargamers but nonetheless we felt the need for slightly more information in the 40 pages of this book. The first eight pages for instance, some of them blank, are taken up with preliminaries before the text proper is arrived at—room in fact for some extra text which might, for instance, give some brief outline of where the battles were fought and what the fighting was all about. For many wargamers this book might well be a first introduction to the period, so just a little more background information would, we think, have enhanced the book's reference value.

## Regiments at Waterloo.

*René North. Indian Cavalry Regiments, 1880-1914. A. H. Bowling. Almark Publishing Co Ltd, 104-106 Watling Avenue, Edgware, Middx. £1.25 (paperback), £1.75 (hardback), each book.*

LATEST two titles from the prolific Almark series, both provide useful references for the military modeller. *Regiments at Waterloo* sets out to be a

basic book covering the Anglo-Allied and French units which fought each other on June 18, 1815. The author is a well-known military artist and writer and he treats a big subject in a lucid and yet comprehensive way. The illustrations in both colour (eight pages) and line between them give a remarkably wide coverage of the subject. The orders of battle and glossary, plus the authoritative text should make this a most useful master reference work for establishing a regiment's presence in the battle, what it did, and where it fought. The line drawings, for which Mr North is well-known, are particularly well done.

The second book does for the Indian Cavalry what author A. H. Bowling did for the British and Scots infantry regiments in previous books. Here he takes each cavalry regiment in turn and by nostalgic old pictures, highly detailed multi-view line drawings, and exquisite small colour drawings, shows how each regiment dressed for different functions and different campaigns. The Indian cavalry was, of course, particularly colourful and this very neat book, packed with 117 little colour drawings and scores of line drawings and pictures, could keep any model soldier fan going for years making and painting a collection of models depicting the famous regiments covered.

**AFV Profile 25: Cromwell and Comet.** *Major James Bingham. Profile Publications Ltd, Coburg House, Sheet Street, Windsor, Berks. 35p.*

LATEST AFV Profile gives an excellent coverage of the two most important British cruiser tanks of World War 2. In fact it differs from other recent Profiles in repeating the Cromwell from the Profile series of 1967 vintage and adding a second half on the Comet. Hence the pictures and artwork on the Cromwell will be familiar to many. However, it makes a very 'complete' coverage. New colour art shows a Comet and an A9 (not featured in the text but presumably added for the benefit of a future bound volume).

## German Heavy Tanks.

*Peter Chamberlain and Chris Ellis. Ducimus Books Ltd, 283 Lonsdale Road, London SW13. £1.25.*

THIS gives a detailed and thorough coverage in text and pictures of all the German heavy tank types produced in the 1933-45 period, with four pages of colour art, line drawings, and extensive specifications. While a useful reference book, we feel that it would have been better on glossy paper. The coarse matt paper and heavy screen used makes some of the pictures very murky indeed and this detracts from what is otherwise a nicely presented volume.

## AIRCRAFT

### The Observer's Book of Aircraft.

*William Green. F. Warne & Co Ltd. 45p.*

### Civil Aircraft Markings.

*J. W. R. Taylor. Ian Allan Ltd. 25p.*

THESE 'hardy annuals' have reached their 20th and 21st editions respec-

Continued on page 542

# AMERICAN HALF-TRACKS



by Peter Chamberlain

## Part 1: Introduction

DURING 1925, the United States Ordnance Department purchased from the French car manufacturer, Citroen, two semi-tracked vehicles that the Citroen firm had developed in collaboration with Alexander Kegresse who had pioneered this type of vehicle during 1911. The two vehicles that were purchased were tested at the Aberdeen Proving Ground as prime movers for the 75 mm field gun.

In 1931, a further vehicle of modified design, a Citroen-Kegresse P.17, was procured for tests and evaluation. Due to the excellent results shown by this vehicle, further development was undertaken by American commercial motor firms for the US Ordnance Department. The first American-built half-track vehicle was designed by James Cunningham, Son and Co; this was tested as a reconnaissance car by the Ordnance Department, and designated Half-Track Car T1. Modified versions of this vehicle were produced at the Rock Island Arsenal and designated T1E1, (M1) T1E2, T1E3. Meanwhile, development of a slightly different type of vehicle, the Half-Track Truck T1 by General Motors was authorised in 1933. This was followed by various other half-track trucks developed specifically as cargo carriers or as prime movers for artillery, with designation from T2 to T9. In the later Half-Track Truck T9, built in 1937 by the Marmon-Herrington Company for the Ordnance Department, first use was made of front wheel drive synchronised with the bogie drive. This vehicle was standardised as Half-Track Truck M2.

The final significant development of this period was the conversion of a wheeled Scout Car, M2A1, into a half-track vehicle by the White Motor Company and Rock Island Arsenal in 1938. The front axle drive of the Scout Car was retained and a volute spring type rear suspension, as used on the Half-Track Truck, M2 was installed. This hybrid vehicle was designated Half-Track



Half-Track Truck T9E1 was standardised as the M2 and built by Marmon-Herrington. It is here seen as an artillery tractor in 1939.

Personnel Carrier, T7. As the performance of this vehicle proved satisfactory, further development of this type of vehicle was authorised in December 1939, on the recommendation of the Mechanised Cavalry Board. This work was carried out by the Diamond T Motor Car Company who developed an improved version of the T7, designated Half-Track Scout Car T14. This vehicle was the prototype of the standard half-track cars and carriers used in World War 2. It was standardised in September 1940 as Half-Track Car M2. Equipped internally with extra seats for the transportation of 14 men, the chassis was standardised as the Half-Track Personnel Carrier M3. While both the M2 and M3 were similar in design and appearance and interchangeable as to major assemblies, the two vehicles differed in tactical use. The M2 car was a prime mover for artillery up to the 155 mm howitzer, and served as an armoured reconnaissance vehicle. The M3 carrier, while primarily a personnel carrier for armoured divisions and motorised artillery, served also as an ambulance, radio carrier, prime mover for artillery and as the basis for a self-propelled gun mount. In practice the distinction between the two in tactical employment swiftly disappeared when America went to war in December 1941.

The first orders for half-track vehicles were placed under the US Ordnance Department's long established peacetime system of competitive bidding. Bids were submitted by various com-



The White Scout Car with added tracks from the M2 Half-Track Truck formed the basis of the whole production series of half-tracks.

panies, notably the Autocar Company, the White Motor Company, the pioneer in this field, who were already making the M2A1 Scout Car, and the Diamond T Motor Company. As the Autocar Co submitted the lowest bid, they were awarded a contract to make 424 half-track cars, M2, in September 1940. This was followed with a contract to the Diamond T Co to develop the half-track personnel carrier M3. As increased requirements for the half-tracks M2 and M3 made manufacture by any one company impossible save by a large expansion of facilities, it was agreed by Autocar, White and Diamond T that all vehicles made by these companies under the supervision of the Ordnance Department would be standardised, having interchangeable components.

Early in 1942, overall requirements for half-tracks were substantially increased. Not only were the manufacturing facilities then engaged in half-track production inadequate to meet the increased demand, but components facilities were also at the limit of their production. It now became necessary to obtain a new source for making these vehicles and their components. Steps were thus taken to use the production facilities of the International Harvester Company, the well-known tractor makers. At this time changes were made in the design of the vehicles and those produced by International Harvester Company (IHC) embodied all changes released at that time for the previous models. The vehicles made by International Harvester were designated Half-Track Personnel Carrier M5 and Half-Track Car M9. These were basically similar to Half-Track Personnel Carrier M3 and Half-Track Car M2, but featured IHC components including an International Red-450-B engine. The body was of homogenous armour plate and a distinctive external feature was the rounded rear corners of the IHC vehicles. The M2 and M3 had face-hardened armour and squared-off rear corners to the body. IHC vehicles were fitted with rear doors.

Two general development projects were contemplated during 1942 and 1943. A so-called 1/2-track model was begun in early 1942; the rear suspension unit was lengthened and other improved features were incorporated, all under the designations Half-Track Trucks T16, T17, and T19. This was intended to reduce

the space between the rear suspension mechanism and the front wheels, which produced high front axle loading and a tendency to hang and strain the vehicle on rough terrain. Tests were successful, but the decision of the Field Artillery to concentrate on high speed tractors as prime movers for artillery resulted in loss of interest in these heavy-duty half-track trucks.

Development of a universal body half-track vehicle, to combine all military requirements for personnel carriers was begun in April 1943. A half-track combining the essential features of the M2 and M3 was accordingly developed and designated Half-Track Car T29. This vehicle was standardised in October 1943 as the M3A2. A similar project for consolidating the M5 and M9 in one basic model resulted in Half-Track Car T31. This was adopted as substitute standard and re-designated Half-Track Car M5A2. Curtailment of the half-track programme began in mid-1943, however, and further limitations were made at the end of 1943. There was no new production except re-manufacturing programmes of the M2, M9A1 cars, and M3 and M5 carriers beyond 1943, and no production of the M2 car and the M5A1 carrier beyond 1944. Complete total built was 41,169 vehicles. Half-track production was, in fact, terminated with the idea of concentrating on full-track vehicles for all the roles which the half-track fulfilled, ie, troop carrier, SP mount, and prime mover. However, due to demand in the field and development delays the half-track remained a widely used vehicle in the US Army until the end of the war in 1945.

(Series continues next month with a model by model description.)

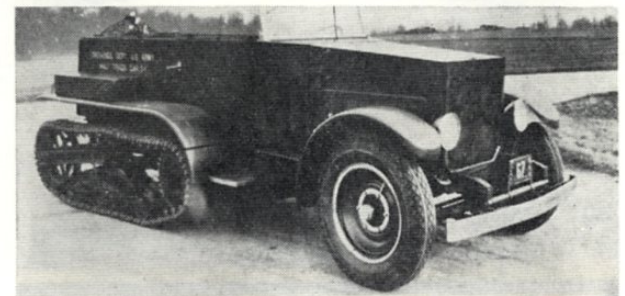
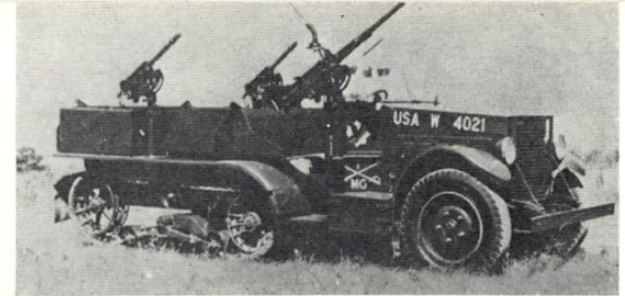

Top: The Half-Track Car T1E1. Above: Half-Track T1. Both were American-built derivations of the French Citroen-Kegresse and represented the first steps into the American half-track field. All pictures courtesy Col R. J. Icks and R. M. Hunnicutt.

## AIR SHOWS 1971

THIS list is based on that prepared by the Merseyside Society of Aviation Enthusiasts and compiled from information supplied by Ministry of Defence, United States Air Force, Air Pictorial, Control Column, Blackbushe Aviation Review, South East Air Review, The Federation of Aviation Societies, British Gliding Association and Hawker Siddeley Ltd. No guarantee can be given that the dates and places mentioned are correct. Intending visitors should check where possible before setting off for any event listed.

May 1	Speke, Lancs.	Air show
	Little Snoring, Norfolk	McAulley Air Trophy
7-9	Jersey	Air Rally
8	Cranfield, Beds.	Open day
9	Doncaster, Yorks.	Barnstormers
15-23	Nympsfield, Glos.	Western Regional gliding comp.
16	Tollerton, Notts.	Barnstormers
22	Mildenhall, Suffolk	Armed Forces Day
23	Seething, Norfolk	Waveney Rally
	Bagington, Warwicks.	Barnstormers
	Hemswell, Lincs.	Flying display
29-6	Newton, Notts.	Standard sport class gliding
30	Old Warden, Beds.	Shuttleworth Trust. WW1 display
31	North Weald, Essex	RAFA display
	Church, Fenton, Yorks.	SSAFA display
	Henlow, Beds.	Round Table air display
	Blackbushe, Hants.	Barnstormers
	Slap, Shropshire	Air display
June 5-6	Fleetlands, Hants.	Navy days
	Aberdeen	Air Squadron aerobatics
10-13	Biggin Hill, Kent	International Air Fair
10	West Raynham	*Air Sea Rescue competition
11-12	Husbands Bosworth, Leics.	Regional gliding competition—sports class
12	Sywell, Northants.	National air race: also at London, Edinburgh, Cardiff and Belfast
	Hawarden, Flint	*Hawker Siddeley Families Day
	Dunsfold, Surrey	*Hawker Siddeley Families Day
18	Mildenhall, Suffolk	Thunderbirds aerobatic team
19	Upper Heyford, Oxon.	Armed Forces Day
	Bentwaters, Suffolk	Armed Forces Day
	Alconbury, Hunts.	Thunderbirds aerobatic team
21	Exeter, Devon	RAFA display
26-4	Lasham, Hants.	Gliding competition
27	Old Warden, Beds.	Shuttleworth Trust. Private flying between the wars
July 1	Abingdon, Berks.	Trans-Atlantic air race. Starts at 08.00 hrs. BST
3	Topcliffe, Yorks.	Open day
	Hatfield, Herts.	Hawker Siddeley Open day
10	Cottesmore, Rutland	RAFA display
	Lossiemouth, Morayshire	Navy day
10-18	Compton Abbas, Dorset	Dorset Regional gliding comp.

11	Booker, Bucks.	High Wycombe air display
17	Sywell, Northants.	Flying for Fun
	Yeovilton, Somerset	Navy day
17-18	Shebden, Hereford	Strongbow air races
24-25	Portland, Dorset	Navy day
	Lee-on-Solent	Navy day
24-1	Booker, Bucks.	Wycombe Regional gliding comp.
25	Old Warden, Beds.	Shuttleworth Trust. Military air day
28	Culdrose, Cornwall	Families day
31	Middle Wallop, Hants.	Army air day
	RAF Stafford, Staffs.	Open day
Aug. 1	Panshanger, Herts.	Barnstormers
7	Chivenor, Devon	NATO air display
7-15	Bicester, Oxon.	Inter-Services gliding competition
14	Alconbury, Hunts.	Armed Forces Day (To be confirmed)
15	Barton, Lancs.	Barnstormers
21	Newtownards, Ulster	Barnstormers
21-29	Sutton Bank, Yorks.	Yorkshire Regional gliding comp.
22	Cowran Grange, Dublin	Barnstormers
29	Old Warden, Beds.	Shuttleworth Trust. Request flying day
	Goodwood, Hants.	Air display
	Blackbushe, Hants.	Barnstormers
29-30	Halfpenny Green, Staffs.	Goodyear air races
Sept. 2-5	Crich, Derbyshire	Grand transport extravaganza
4	Cranfield, Beds.	Light Aircraft show
	Litt'e Rissington, Glos.	CFS open day
5	Cranfield, Beds.	RAeS Garden Party
18	Colt'shall, Norfolk	Battle of Britain day
	Finningley, Yorks.	
	Abingdon, Oxon.	
	St. Mawgan, Cornwall	
	St. Athan, Glam.	Esso Tiger aerobatic display
	Biggin Hill, Kent	
	Leuchars, Fife	Veteran and Vintage rally
	Rochester, Kent	
	Booker, Bucks.	Barnstormers
	Old Warden, Beds.	
	Sibson, Hunts.	Shuttleworth Trust. Flying day
	Old Warden, Beds.	

## CONTINENTAL EVENTS

May 23	Celle	Luftwaffe open days
	Neuberg	
30-31	Agno, Switzerland	Swiss Aero Club display
26-6	Paris	
June 13	Weisbaden, Germany	Paris Air Salon
17-19	Dubendorf, Switzerland	Armed Forces Day
		Swiss Air Force weapons meet
19-20	Brustem, Belgium	Belgian Air Force Open day
Aug. 15	Coxyde, Belgium	Wings day

\* Public not admitted



An unusual Halifax was L9619, a Mk II seen here without a dorsal turret and in the hands of 10 Sqn. She joined 10 Sqn in November 1941 and crashed on the night of February 15/16. Note the camouflage patterning and an almost invisible red serial ahead of the 'E' on the upper surface colouring (Imperial War Museum).



## Part 26: The early Halifax

HANDLEY PAGE, whose recent liquidation was an inglorious ending to an illustrious firm, supplied the Royal Air Force with long-range bombers for nearly fifty years. It was natural for the company to tender designs to pre-war heavy bomber specifications. Its Hampden proved successful and the firm viewed with interest Specification B.1/35 for a large two-motor heavy bomber. This specification had evolved after lengthy discussion but was soon eclipsed by the two important 1936 requirements, B.12/36 for a four-engined bomber and P.13/36 for a high-performance aircraft powered by two engines. Handley Page tendered for the B.1/35 but before proceeding adapted its design the HP 55 to P.13/36 which consequently became the HP 56. Two Bristol Hercules engines had been originally chosen, but greater power seemed likely to be available from the new Rolls-Royce Vulture.

Handley Page planned the '56 with an all-up weight of 45,000 lb around two of these engines to carry a greater load further than would the HP 55. In April 1937, two prototypes were ordered by Air Ministry along with two of the competitor, the Avro 679. Serials L7244/45 were allotted.

As work advanced a mock-up was built. It soon became obvious that the Vulture programme was in difficulties. Air Ministry suggested to Handley Page that as an insurance against the failure of the Vulture, and indeed the Avro design, the

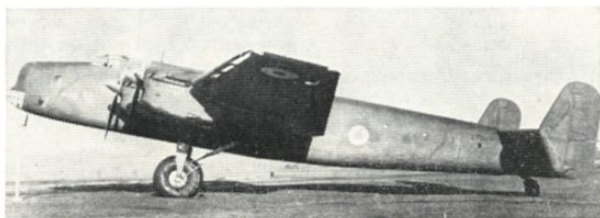

L7244, the first Halifax prototype, in her initial finish with Type B fuselage roundels. Note the leading edge slots.

HP 56 should be re-thought, enlarged and powered by four Rolls-Royce Merlins. Handley Page were reluctant to do this. Eventually, seeing the official demand more like an ultimatum, they gave way and re-designed the machine around four engines. Basically its shape was unaltered, the bulky fuselage stemming from the need still for the aircraft to be a possible troop carrier, which eventually it became. Enlargement of the design, however, pushed the weight to around 50,000 lb.

Two prototypes of the new aircraft, the HP 57, were ordered on September 3, 1937. On January 7, 1938, the first production order for 100 machines to Specification 32/37 was placed. Construction of the first prototype began the same month. By October 1938, plans called for 1,500 Avro 679s, 1,500 Short B.12/36s and 500 HP 57s. To speed and ease production the machine was built to a split assembly system.

Fear that the aircraft would require a long take-off run led to its component parts (the machine was easily broken down as in the case of the other bombers of this period, to fit the standard packing cases) being taken to Bicester just as the war commenced. Here the parts were re-assembled and on October 25, 1939, aircraft L7244, in Dark Green, Dark Earth, and Night finish with Type B roundels, made its first flight. As with the Manchester, no turrets were fitted, for this was really an aerodynamic trials aircraft powered by four Merlin Xs. It also had wing leading edge slots, a popular feature with the firm, and slotted flaps. Slots were never featured by production aircraft for they proved to be not needed and in any case were deleted to make room for balloon cable cutters which, in the event, proved of little value.

The prototype flew from Bicester, Boscombe and Radlett whilst L7245 was being completed. This aircraft, fully armed, first flew on August 17, 1940, and from the start was in the new prototype colours of Dark Green and Dark Earth with Yellow under surfaces. Unusual were the bold black serials under the mainplane in trainer style. After initial handling it was passed to Boscombe Down, where it stayed for most of its time, used for general development and armament work until November 1941, when it crashed on take-off.

Already Handley Page production lines had swung over to the Halifax, as the new bomber was named. On April 30, 1940, English Electric had received an order for 400 Halifaxes and other production lines were to be established by the London Aircraft Production Group led by the London Passenger Transport Board, by Fairey at Stockport, and by Rootes Group at Speke.

On October 11, 1940, the first production aircraft, L9485 (Merlin X), made its first flight painted in Dark Green and Dark Earth finish with its Night under surfaces terminating in a wavy

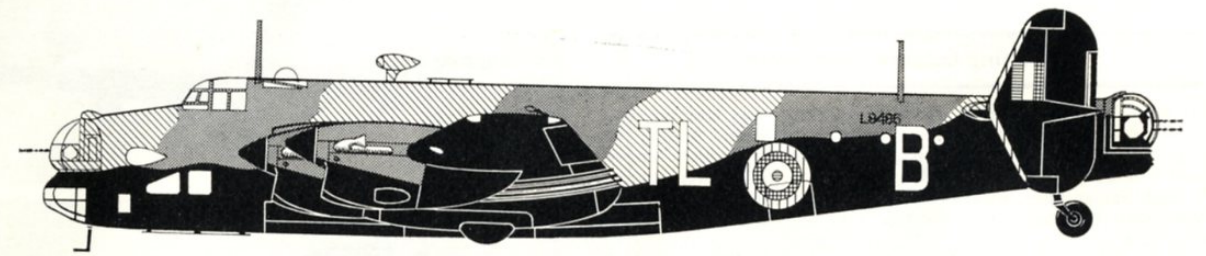

COLOUR KEY

	RED		DARK GREEN
	WHITE		DARK EARTH
	BLUE		BLACK
	YELLOW		TL: B DARK GREY CODES
			OTHERS MEDIUM GREY CODES

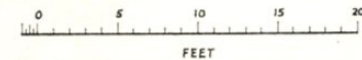

Above, top to bottom: L9486:TL-B as recorded during AFDU trials at Duxford March 29, 1941. Serials were Dull Red and the codes were a dark shade of grey. L9582:TL-T depicts the higher ending of the black areas and was recorded in these markings October 28, 1941. Medium grey codes. R9367 was recorded January 14, 1942. The camouflage on the under surfaces terminates higher still in a very wavy line. Codes medium grey. The 'yellow' wing and tail leading edges on the drawings refer to the application of a buff de-icing paste common on bombers in 1941-42.

line roughly mid-way up the fuselage sides, a feature of all the Mk Is when they left the factory. Like the Manchester and Stirling, the Halifaxes had red serials which were still being applied when the Mk I was phased out, and these appear to have been retained even into 1942. Its maximum take-off weight was now 55,000 lb—a further increase which could only detract from its performance. Two days after its flight, L9485 passed to Boscombe for trials which continued into December, by which time L9486 had joined her. Both machines had the standardised armament of two nose and four tail guns in Boulton Paul turrets. Boscombe's trials revealed a top speed of 262 mph at 18,000 ft on 50,000 lb. Bomb load/range assessment was 1,740 miles with 8,500 lb load or 1,000 miles with 13,000 lb. Take-off run at 55,000 lb was 1,020 yards, initial climb 750 ft/min, and service ceiling 22,800 ft. Dimensions were span 98 ft 10 in, length 70 ft 1 in, wing area 1,250 sq ft.

Under the review of current projects in May 1940, Handley L7244, the prototype Halifax, in later style with Type A fuselage roundel.



Page were ordered to stop work on their B.1/39 'super bomber'. All effort was now to be on the Halifax in view of the Manchester's troubles. So keen now was the firm on the machine they had initially cold-shouldered that they adamantly maintained there was no need for any other four-engined bomber, especially when rumours circulated that Avro were planning a four-engined Manchester development.

On November 5, 1940, No 35 Squadron re-formed attached to A & AEE Boscombe Down under Wing Commander R. W. P. Collings, there to become acquainted with the first production machine and L7245. Production was slow and when the squadron moved to more permanent quarters at Leeming it took L9486 on loan. On November 23, L7244 was attached to the squadron, a very useful addition for it had dual control.

The squadron moved to Linton-on-Ouse on December 5 and further handling, fuel consumption trials were held, along with conversion training. Before the squadron could operate, flight engineers needed to be trained. This could only be done on the squadron, which now had three aircraft assigned to it, L9486, '87 and '89. Further deliveries took place in February and the aircraft were soon wearing their grey 'TL' coding, a rather dark shade of grey and certainly darker than Medium Sea Grey on the machines that I saw. TL was painted forward of the port side, aft on the starboard as on L9486:TL-M and L9489:TL-F.

By early March 1941, six crews were operationally fit and on

Continued on next page

## Bombing Colours—continued

the night of March 10/11 the first operation was laid on with Le Havre docks as target. It was a cloudy night and finding the target was difficult. Flak damaged one aircraft which limped home. Another fell to a more unlucky fate when, over Surrey, a night fighter pilot misidentified L9489 and shot it down. Next night, two Halifaxes made the first raid on Germany, attacking Hamburg.

In mid-April, news broke that a second Halifax squadron would form, No 76, which began to rise from a third flight of 35 Squadron. On May 1, No 76 Squadron came into being at Linton. On May 12, the enemy, doubtless aware of the lair of the new bombers, attacked their airfield, damaging some aircraft in hangars and on dispersals.

No 76 Squadron took six weeks to work itself up for action, despatching its first sorties on June 12 to the oil refinery at Huls, Kiel, Duisburg and Hanover had now felt the weight of Halifax bombs and the two squadrons were now operating alongside.

Daylight attack by heavy bombers was a cherished idea to the Air Staff who considered this quite feasible if fighters flew diversions and the Blenheims of 2 Group could pave the way. The first day raid by Halifaxes was mounted on June 30 when six crews of 35 Squadron set off to attack Kiel from 18,000 feet, the height at which the Halifax I best performed. To increase their fire power the bombers now had beam guns, but this did not save two of them falling to enemy fire. Although 35 Squadron expected more daylight raids they were still considered too costly, so night raids on targets such as Frankfurt and Magdeburg followed.

Main parts of the first English Electric Halifax reached the flight shed at Salmesbury on June 24 and on July 9 a second order was placed with that company for 250 machines. V9976, their first aircraft, flew on August 15 and was ready for delivery on September 20. At Cricklewood and Radlett, Handley Page had not wasted time. Resulting was a refinement of the first version of the Halifax. Early machines were designated Mk I, Series I and before the production type had even flown it had been decided to re-stress the aircraft to 60,000 lb, a feature of the Series II. An increase in fuel load from 1,392 to 1,636 gallons and maximum possible fuel load from 2,242 to 2,363 gallons resulted in the Mk I Series III. A few of the latter aircraft are believed to have had 1,390 hp Merlin XX engines, but these were more a feature of the HP 59 Halifax II Series I which had increased power to combat the extra load. This version also had greater fuel capacity, 1,882 gallons (2,572 in overload state), but the most distinctive item of the Mk II was its two-gun 'Hudson-like' Boulton Paul dorsal turret. L9515 was set aside as prototype, completed in June 1941 and first flown on July 3, 1941. It was much superior to the Mk I, production of which terminated in September 1941 with L9608. The first production Mk II was V9976 and the first from the parent company was L9609 which flew in September 1941.

Meanwhile, operations by both squadrons were well under way. The most spectacular as yet had been on July 24, 1941. A large-scale daylight raid on Brest had been planned for all the medium and heavy bombers in an attempt to sink or disable the *Scharnhorst* and *Gneisenau*. But the failings of the Manchester caused these machines to be withdrawn. Then, the day before the raid, *Scharnhorst* sailed. Stirlings were immediately despatched to attack her and although their operation was gallantly flown, little was achieved. Next day, Halifaxes of the two squadrons

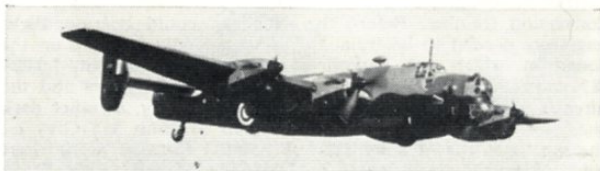

A late production Mk 1, showing the black finish on the nose, a factory finish of about September 1941 (Real Photographs).

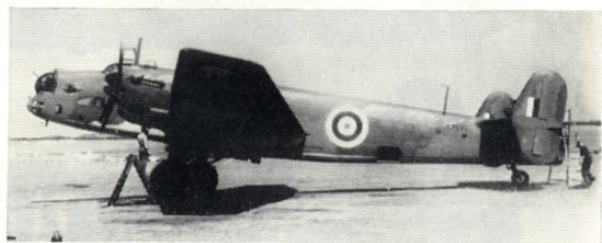
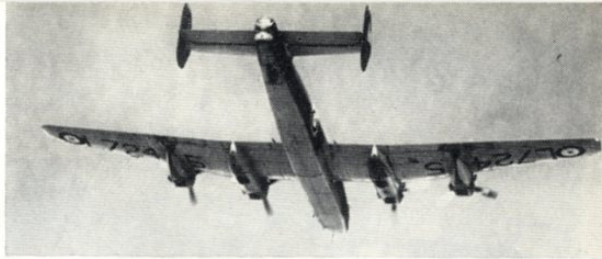

L7245, the second prototype, in 1941 finish with full armament and with under wing serials (Real Photographs).

raided her at La Pallice, losing a third of their number. Under-armed, the Halifaxes were clearly unsuited for day raids and not until the end of the year did they operate by day again.

The first Berlin raid was mounted on July 25/26 and on September 10/11 Halifaxes, using Stradishall as a forward base, set off for Turin. It was a long, long journey, taxing to the extreme, as the bombers laboured over or between the high Alps. When they came back from their long journeys, three of the aircraft crashed from fuel shortage, one of them being hopelessly lost. In 1941, Bomber Command still had much to learn.

Production Mk IIs began to leave the Handley Page works in October 1941, by which time the second production source,

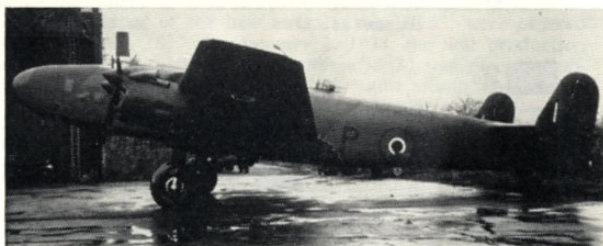

L9515 in Dark Green/Dark Earth/Yellow prototype finish. She was the trials installation aircraft which led to the Mk II Series IA. Here she features the revised nose, has a flattened four gun dorsal turret and lengthened nacelles—all features to improve performance. Photograph was taken in the winter of 1942-43.

English Electric Preston, was a fully going concern and made its first squadron delivery of V9979 on October 25 to No 35 Squadron on the day when another Mk II, R9364, from Handley Page's second batch also joined 35 Squadron. L9611 had joined 76 Squadron the previous day, and Mk IIs slowly replaced the Is. The Mk II first operated on November 25/26, when V9979:TL-E and V9980:MP-B were part of the force.

Training for the Halifax crews had hitherto taken place on squadrons, but an operational formation is ill-placed if it has major training duty to perform. In October, by which time Halifax deliveries were sufficient, No 28 Halifax Conversion Flight was established using, amongst others, L9486, '91, '96 and L9509.

Berlin, Essen, Hamburg and Stettin—all were attacked in the closing weeks of the year. Production was building up and a third Halifax squadron, No 10, formed at Leeming. It received its first aircraft, R9367, on October 24 and although it used few Mk Is, had mainly Mk II aircraft from the start. It flew its first operation on December 18.

The German battlecruisers were both at Brest and there was constant fear lest they put to sea to sink vital British merchant

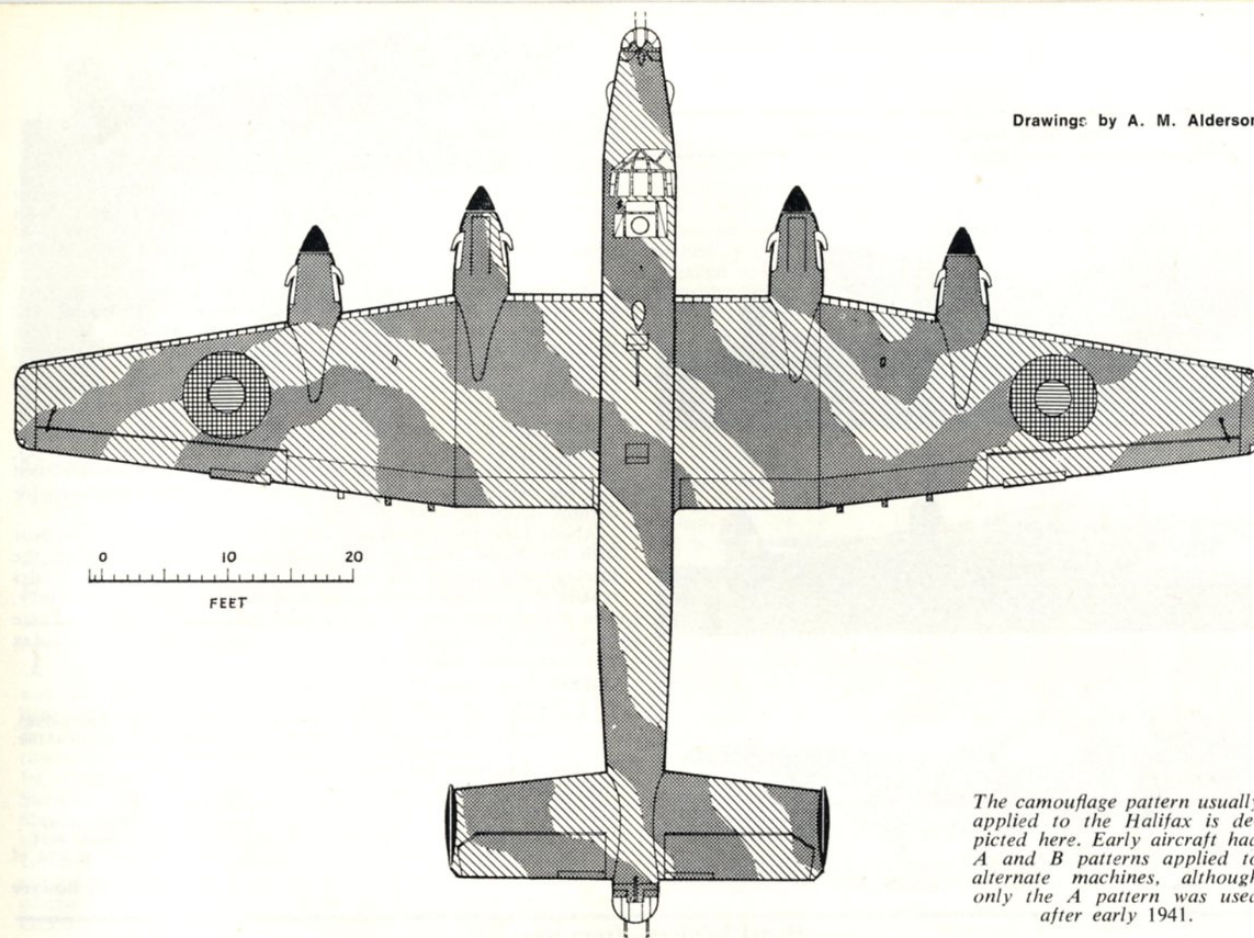

Drawings by A. M. Alderson

The camouflage pattern usually applied to the Halifax is depicted here. Early aircraft had A and B patterns applied to alternate machines, although only the A pattern was used after early 1941.

shipping in the North Atlantic. Therefore it was decided to attempt another day raid for night attacks were achieving little. On December 18 a force of Stirlings, Manchesters and 18 Halifaxes (six from each squadron) set off for the raid and although the fighters came in, only one Halifax was lost. The raid was nevertheless not very successful and so another attack was launched by Halifaxes only on December 30, when three of the 18 despatched were shot down.

Nevertheless, all was not well with the Halifax. Additional all-up weight had resulted in an under-powered machine, and the massive dorsal turret coupled with the entire nose and the six striking fuel jettison pipes were excrescences which led to excessive drag. Another unhappy feature of the aircraft was its tendency to spin when heavily loaded. All these features needed urgent attention, particularly the spinning characteristic. R9534 on the line in March 1942 was set aside as a trial installations aircraft and was stripped of many items. A new nose of curved streamlined form was fitted, a metal nose for aerodynamic tests reproduced in perspex for trials on DG276. A flatter Boulton Paul dorsal turret was fitted. Fuel jettison pipes were removed, exhaust shrouds modified, Merlin 22 engines with reduced radia-

tor area were installed, bomb doors were modified to allow carriage of larger weapons and much internal gear stemming from the original specification was removed. But the arrival of production aircraft featuring these points came months later.

In the meantime, a new variant appeared, the Mk II Series I (Special). From these aircraft the nose turret and bomb aimer's canopy were replaced with a so-called 'Z Fairing'. Dorsal turrets were removed, as were the jettison pipes. Exhaust shrouds were modified, but the triangular fins were retained. It was discovered that the spinning troubles arose from these. Air flow around the fins and rudders was found to cause rudder stalling which put the aircraft on to its back in a dive. 'Square' fins were tried on R9534 but it was 1943 before Halifaxes appeared on the squadrons with them.

Modifications were also made to the undercarriage on L9520 between April and May 1941 by Dowty which led to the Mk V. Rotol experimented with fluid de-icers and three-bladed wooden propellers.

Ventral turrets attracted the armament experts throughout the war. Trials were conducted in 1942 with W7650 but few other

Continued on next page

L9530:MP-L of 76 Sqn frequently flown by Pilot Officer Christopher Cheshire, brother of the famed Leonard Cheshire, VC. Delivered to 76 Sqn in June 1941, she was lost during a Berlin raid of August 12/13, 1941. The aircraft is wearing medium grey codes and has an extension of the black finish much in evidence, while the grey serial has been re-positioned (Imperial War Museum).

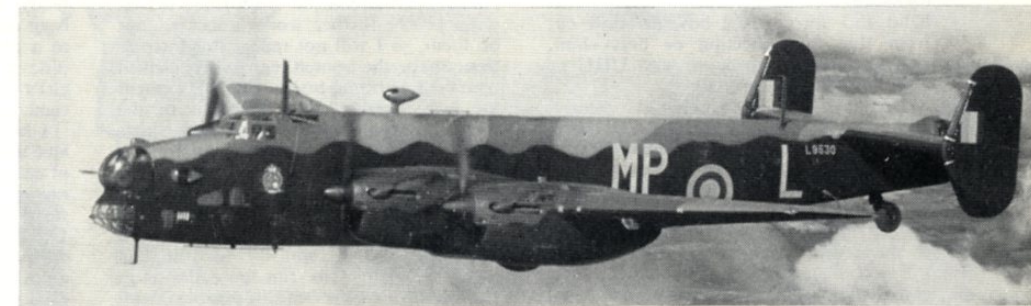

## Bombing Colours—continued

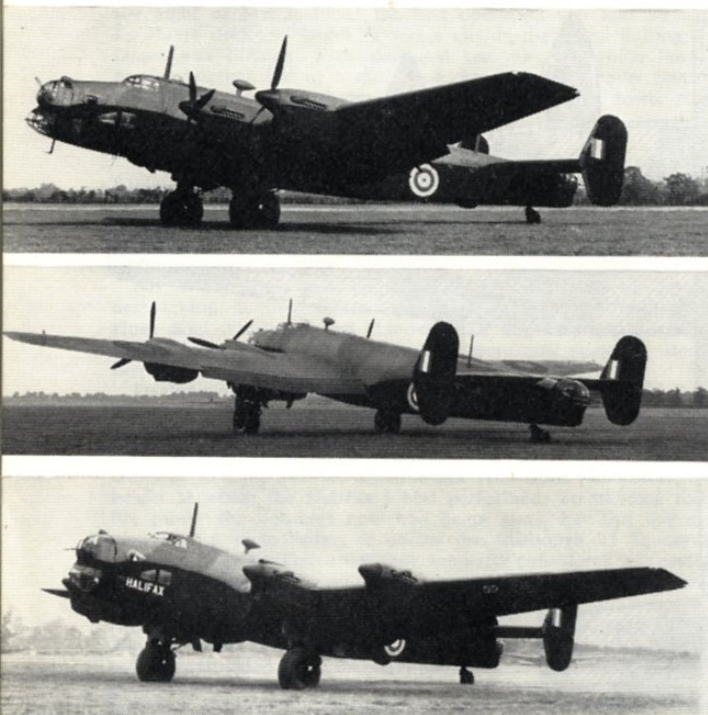

**Above:** R9441 joined 35 Squadron in February 1942 and was a Mk II. The photograph, probably taken in February 1942, shows her roundels and fin striping with their white areas covered in what appears to be a grey wash. Later she served with 76 Sqn and No 1652 Conversion Unit.

**Left:** L9601 photographed in September 1941 at Radlett. It became MP-F of 76 Sqn and was later used by 78 Sqn in 1942 for training purposes mainly. **Bottom left:** Another Mk I at Radlett showing slight camouflage differences, for the detailed drawings prepared were not slavishly followed. It is probably L9609, christened by Lady Halifax in September 1941 and later used by 76 Squadron as MP-V ('Flight' photos).

aircraft appear to have had them. V9977 was fitted with a large plastic cupola and it arrived at the TFU Hurn on March 27, 1942. Here the first H2S blind bombing equipment was installed and the machine began trials in April 1942. V9985 was used for dummy drops of 4,000 lb bombs.

About June 1941, Halifaxes on the squadrons began to appear with the Night areas of their paintwork extended high on the fuselage side, terminating in a wavy line in common style. Codes remained grey and serials positioned further aft were also grey. The straight line ending to the black was a 1942 feature. There were very few changes in markings, and by 1942 the Halifax was very much a going concern.

### Halifax production 1940/early 1942

Mk I: L9485-9534, L9560-9684, L9600-9608.  
Mk II: L9609-9624, R9363-9392, R9418-9457, R9482-9498, R9528-9540, V9976-9994, W1002-1021, W1035-1067, W1090-1177, W1141-1190, W1211-1253, W1270-1276.

### Halifax Squadrons 1941/early 1942

No	Identity letters	Example	Bases
10	ZA	C:L9624	Leeming
35	TL	P:L9511	Leeming, Linton-on-Ouse
76	MP	B:L9565	Linton; to Middleton 6.41
102	DY	T:R9449	Dalton; equipped at end of 1941

Michael J. F. Bowyer

## Model Soldiers—from page 521

set, can be sanded down to represent the hair drawn back into a 'bun' (Fig 5).

The dress and apron are now applied, and for this use strong tissue-paper; Kleenex is ideal, which is stuck directly to the figure with Bostik gum, such as is used for sticking paper cuttings in a scrapbook. This gum impregnates the tissue-paper, and as it dries, a process which is quite rapid, the tissue can be drawn into creases and folds to represent cloth drapery (Fig 6). When it has dried out completely, mix some more Isopon and coat it liberally over the complete area of tissue, and allow it to set before sanding and shaping the garment to its final shape. The apron is fitted in exactly the same way, as is the cape and collar (Fig 7). Isopon is now applied to wrists and arms, and in due course sanded down to make the sleeves and cuffs. A waist-band and apron-string bow are now cut from thin lead sheeting or brass-shim, and attached to the figure with UHU or Araldite adhesive (Fig 8).

The next step is to make the boater, and for this a piece of sheet lead or brass-shim is cut to circular shape and fixed to the flat top of the head with Isopon, it makes an excellent adhesive in this case, with a large blob of the same material on top, which when set is sanded down to shape (Fig 9).

Finally, an umbrella or sun-shade is constructed from plastic scrap and tissue,

and cemented in place in the right hand. The figure is now ready for fixing to a temporary base for painting. I actually soldered a strip of thick brass to the advanced left foot, and carefully cut it away after painting was completed.

This is a fairly complex conversion involving the use of new materials and techniques, but with care and consideration will result in a very pleasing and attractive little figure.

### CONVERSION 2

The Officer of Life Guards in undress uniform demands the following Historex parts: torso, infantry officer's booted legs, left leg at attention, right leg marching; suitable head and arms.

It is understood that all moulding seams will be removed from these plastic parts before further work is carried out on them, so I will not repeat this instruction. Shape the booted legs to give British type field or riding boots (Fig 10). Cement the legs together, then fit them to the torso. Add Milliput to form tunic skirts and breeches flare, allowing it to dry thoroughly before proceeding. Heat may be applied from a fan-heater or hair dryer to accelerate the setting process. Trim side-whiskers, etc, from whatever head you have chosen, and try for the late Victorian look. Also trim the collar as in Fig 11. Cement the head in position, with

a natural turn of the neck towards the right, and make good the join. Cut the tunic front-opening, and level off the tunic skirts. Using the dimensions given in Fig 12, fashion breast and side pockets from very thin plastic sheet and fix them in place. A liquid cement is preferable for this stage. Apply some more Milliput to the head, and when set sand and shape as in Fig 13. Now cement the arms in place and add to the left hand a riding whip fashioned as in Fig 14 from plastic rod and strip. Fit plastic strip spur-straps, and drill both heels to receive short lengths of sprue which form the spurs (Fig 15). Lastly, cut shoulder straps and fix them in position. Carry out a check that all stages have been completed, and make good all joins.

Cement the figure to a temporary stand ready for painting. When painting has been completed, the figure should be fixed to a permanent base in the walking attitude shown in the photographs, with the girl's left hand resting on the man's bent right arm.

I hope this exercise in the use of new and unfamiliar materials will prove to be of considerable benefit, and that the techniques acquired will stand you in good stead in future modelling projects. Though these conversions may seem more difficult than previous ones, they are quite straightforward if you take them in easy stages.



## Modelling the armies of the Napoleonic era for wargames by Robert C. Gibson

### Part 7: The Prussians

THE Prussian Infantry of the Guard, like Napoleon's Guard regiments, was composed of 'normal' infantry and light infantry. 'Normal' regiments were dressed in dark blue jackets with a double row of seven buttons down the front. The 1st Foot Guards had red collar and Swedish cuffs both with two white 'litzens'. Shoulder straps were white, buttons silver, and coat tail turnbacks red. The 2nd Foot Guards had similar jackets with red cuffs and dark blue three-button cuff patches. The buttons were silver. Both Guard Grenadier Regiments were similar to the 2nd Foot Guards (without 'litzens'), being distinguished by white shoulder straps with a red 'A' for the 1st, and red shoulder straps with a yellow 'F' for the 2nd Regiment.

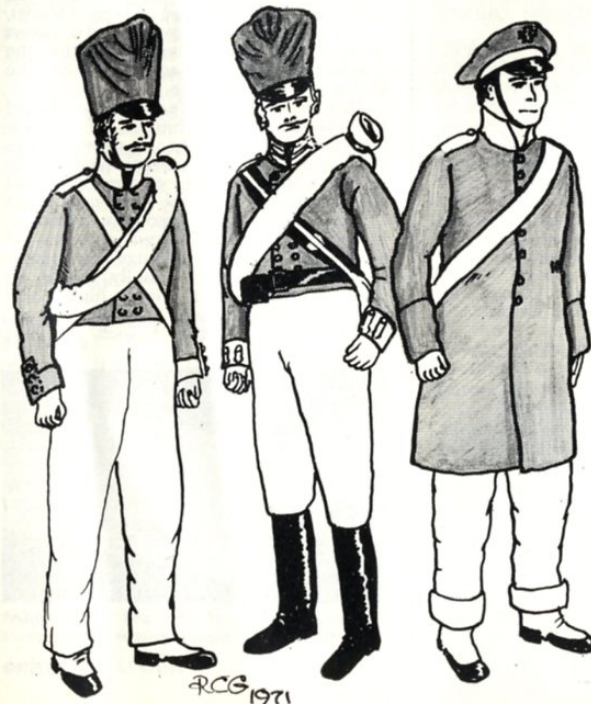

The Light Infantry wore dark green jackets; the Guard Jaeger Battalion had red collar, Swedish cuffs, shoulder straps and piping on the dark-green turnbacks. Two yellow 'litzens' were worn on collar and cuffs; the Guard Schuetzen Battalion had black collar, shoulder straps and cuffs (all but the cuffs piped red), dark green cuff patches and turnbacks. Collar 'litzens' was yellow. All regiments or battalions wore black shakos (which were covered with black waterproof covers on campaign), grey blanket rolls and breeches, plus black knee-boots. Light Infantry wore black belts, others white. White haversacks were often worn on campaign.

Officers were dressed the same as the men but with silver or gold 'litzens' where white or yellow are mentioned above. They wore a silver waist sash.

### Line Infantry

Line infantry wore the dark blue jacket with collar and cuffs in the colour of the province:

Province	Colour
East Prussia	brick red
West Prussia	crimson
Pommerania	white
Brandenburg	light red
Silesia	yellow
Magdeburg	light blue
Rhineland	madder red
Westphalia	light red

The cuff patches were dark blue with three buttons. The coat turnbacks were red and all buttons brass. The regiment within the province was identified by the colour of the shoulder strap:

Regiment	Colour
1st	white
2nd	red
3rd	yellow
4th	medium blue

Trousers were grey, as was the blanket-

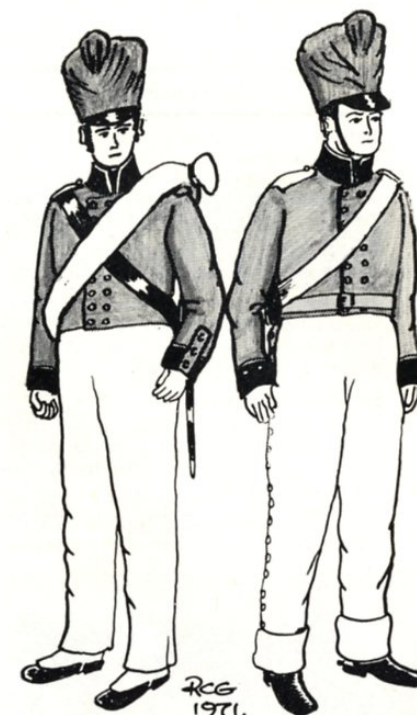

Prussian Artillery troops in campaign dress. Left is a Foot Artillery private and right a Horse Artillery private. Colour details in text.

roll. The boots were black. Shako detail was as given for the Guard. Belts were white except for the third battalion of each regiment, whose men were called Fusiliers and wore black belts.

### Light Infantry

Line Jaeger battalions wore the same *Continued on next page*

**Left:** Prussian Infantry showing (from left to right) privates of the Line Infantry, Guard Jaeger, and Landwehr. Colours are given in text. **Below:** Landwehr, Line, and Guard Jaeger Infantry figures respectively, converted as described in text. **Bottom:** Crew of three men of the Foot Artillery with 4 pdr gun.



uniform as the Guard, without 'litzen'. The East Prussian battalion had red shoulder straps, and the Magdeburg battalion had yellow shoulder straps. Breeches, boots and equipment were as for the Guard.

Line Schuetzen battalions wore the Guard uniform without 'litzen'. White shoulder straps were worn for the Silesian battalion and red for the Rhine-land battalion. Breeches, boots, etc, were the same as for the Guard.

**Landwehr Infantry**

The Landwehr wore dark blue 'litewkas' (¾ length coats) with a double row of seven buttons on the front. Provincial colours were:

Province	Collar	Buttons
East Prussia	brick red	silver
Kurmark	red	brass

Province	Collar	Buttons
Neumark	red	brass
West Prussia	black	silver
Fommerania	white	brass
Silesia	yellow	silver
Westphalia	green	silver
Rhineland	madder red	brass
Elbe-land	light blue	brass

The soft peaked cap had the band and the crown piping in the collar colour. Trousers were grey, and equipment as for the line infantry. The shoulder straps identified the battalion within each provincial regiment, ie, 1st white, 2nd red, 3rd yellow, 4th light blue. The cap had a silver Maltese cross above the black peak.

**Mounted Officers**

Mounted officers wore the uniform of their regiment, with grey overalls buttoned up the outside leg. The seam stripe was generally red, with buttons in regimental metal colour. Horse furniture was a 'square' shabraque in dark blue or dark green, edged red.

**Artillery**

**Uniform:** The Foot and Horse Artillery used the same colours in their uniforms, the Foot Artillery wearing infantry-style uniforms and the Horse Artillery dragoon-style uniforms. The jacket was dark blue; collar and cuffs were black with red piping. Foot artillery had dark blue cuff tabs with three buttons, the horse artillery had Swedish

cuffs. Coat tail turnbacks were red and buttons brass. Guard Artillery wore yellow 'litzen' on collar (Foot and Horse) and cuffs (Horse only). Belts were black for Foot and white for Horse artillery. The black-covered shako as for the infantry on campaign. Boots were black and trousers grey. Horse artillery wore grey overalls buttoned up the side, and the blanket roll was also grey.

**Limbers:** The Prussian limber of 1815 was essentially similar to the American Civil War limber: the gun was hitched on to the back of the limber. The number of horses varied according to the gun towed and the role:

Equipment	Team
4-pounder, Horse Artillery	4 to 6 horses
4-pounder, Foot Artillery	4 horses
8-pounder, Horse Artillery	6 to 8 horses
8-pounder, Foot Artillery	6 horses
12-pounder, Foot Artillery	8 horses

**Guns:** The gun shown in the photographs is similar to the Prussian 4-pounder, but the Airfix French Artillery gun is closer to the original. Other Prussian guns are available (in white metal) in 20 mm size from Miniature Figurines Ltd and Rose Miniatures, and several of the larger mail order stockists can supply these.

Prussian guns and limbers were sky-blue in colour (German Light Blue in the Humbrol range is suitable) with black metal fittings, and bronze barrels.

# NEW

## KITS AND MODELS

**Modeldecals: US Navy transfers**

ONE of the most attractive sheets of markings to be produced by Modeldecals has recently been released. The ninth in their series, this seven-colour sheet depicts aircraft of the US Navy at present in service and contains items for an A-1J Skyraider of VA-176 on the USS *Intrepid*, an LTV A-7E Corsair from VA-195 (this aircraft appeared at last year's Farnborough Air Show) and an SH-3A Sea King from the USS *Randolph*. The markings can be used on the Sea King and Skyraider from Airfix and the A-7D from Revell.

At 38p these superb decals come complete with an excellent instruction sheet detailing the positions of the many separate items on the model. Colour notes and short histories of the aircraft featured are also included.

Without doubt, Modeldecals sheets have now become established as leading specialist transfers manufacturers and can be relied upon for accuracy and first-class workmanship.

Modeldecals sheets can only be obtained by post from Modeltoys, 246 Kingston Road, Portsmouth. An additional 5p must be added to the price for return postage and packing. *A.W.H.*

**AMT: 1:25 scale truck kit**

TWO complementary models which are sure to appeal to collectors of commercial vehicles have recently been received from Jones Bros of Chiswick. The models are of a Peterbilt 'Cabover' V8-powered prime mover, and a Fruehauf semi-trailer, both to 1:25 scale. They are excellent models, well detailed and with large numbers of small parts, chromed where appropriate. The models are made by AMT, and are therefore typically American in the subjects they portray. Other vehicles in the range include fuel tankers and car transporter semi-trailers and California Hauler prime mover unit. The cab unit and the trailer cost £4.35 each, which is worth paying if you're really interested in the subject, though rather too high, we think, to attract beginners. *P.W.*

**Graham-Farish: N gauge van and transfers**

FROM Jones Bros of Chiswick we've had a sample of the latest Graham-Farish N gauge van, an SR 12 ton type finished in grey. As mentioned in a recent article by Norman Simmons, the coupling has been simplified a little in its form of mounting so that it now relies on the natural 'spring' in the plastic for its flexibility. This eliminates the rather prominent bulge under the buffer beam which was associated with the original sprung coupling and offers a big visual improvement all round since there is now a complete buffer beam on the model. So far as we can determine, the change has little

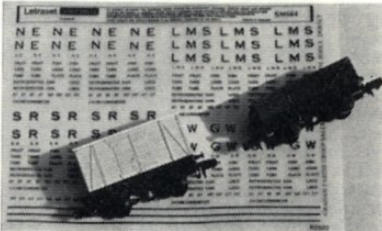

The Graham-Farish N scale dry transfers and a van (on left) with the less conspicuous coupling compared to the old type on the wagon.

or no effect on the model's willingness to couple and uncouple. Unlettered, the van costs 32p, postage extra.

All the Graham-Farish models in N gauge are supplied pre-coloured but unlettered. As we previously mentioned, Farish supply a Letraset-type dry transfer sheet so that the modeller may apply wagon markings of his choice. As Letraset is quite easy to apply to the flat sides of a wagon, this seems to be a very good idea. The wagon can also be pre-painted first if a different colour is desired. Each sheet comes in either black or white with the standard lettering of the four pre-nationalisation companies (GWR, LNER, LMS, SR) and a good selection of initials, small numbers, 'Tare', 'Tons', and similar types of wagon lettering, all very neatly and accurately printed. We think this sheet will also be of value to both TT and OO gauge modellers, since much of the lettering supplied could also be used for the smaller style of markings in these larger sizes. Price per sheet is 38p and Jones Bros of Chiswick hold stocks. *C.O.E.*

**Riko: OO gauge tunnel mouth**

AN inexpensive scenic item distributed by Riko is a plastic moulded tunnel mouth in a somewhat 'Victorian' style, complete with castellated parapet. It is the single track variety and is designed to be built into permanent scenery. Spigots round the inside edge of the opening will take a card insert, if desired, to represent the tunnel lining. By cutting off the lower five or six courses of masonry it would also be possible to use the tunnel mouth on narrow gauge, TT,

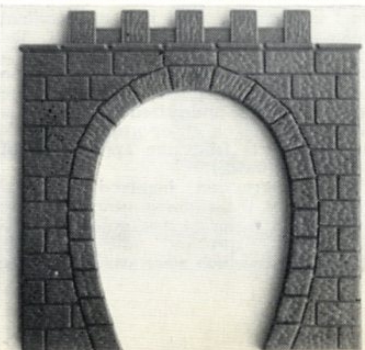

or N gauge layouts. In the latter case, however, it would be necessary to scribe more courses into the moulded masonry finish to retain scale appearance. Priced at 10p, it should be available from most model railway stockists. We think this item would also interest wargamers looking for a protected gateway for fort or walled city models. *C.O.E.*

**Tamiya: 1:35 scale British troops**

THE set of British infantry illustrated and previewed in our March 1971 issue is now on sale, priced at 24p. Three figures are provided, all riflemen in battledress in standing, standing firing, and kneeling positions. However, there is considerable variation possible in the actual pose since trunks, legs, arms, etc, are all separate components. Using the techniques described by Roy Dille in recent articles it would be possible to alter the parts and assemble the figures to any desired position. The khaki coloured plastic is neatly moulded and the instruction sheet is easy to follow. The only mild criticism is that the figures have a slightly Japanese stature from some aspects, short in leg and with rather oddly-shaped boots. These points can be remedied by the modeller easily enough, extra height, for instance, being given by adding insert pieces in the legs in the usual manner. Being to 1:35 scale they are intended expressly to go with the Tamiya tanks and they look a little small when compared to 54 mm (1:30/1:32) scale figures. In sum, however, they represent good value for money. Our samples came from Jones Bros of Chiswick, who can supply by post, postage extra. *C.O.E.*

**France Jouets: 1:5 scale rifles**

THE French plastic kit makers reach consistently high standards of manufacture and originality, and carrying on the tradition set by Heller and Historex comes a new range of models which could well find favour among weapons enthusiasts outside France. Sold under the France Jouets label, this is a series called 'Rifles of the 1914-1918 War', five models in all representing the main weapons used by the combatant forces of the period. Specifically these are: the Lebel M1886/1893 (France); Mauser M1898 (Germany); Parravicino-Caracano M1891 (Italy); Springfield M1903 (USA); and Lee-Enfield Mk III (Great Britain).

All are to a common 1:5 scale and the individual models come neatly packaged in card trays with transparent slip-on covers, rather reminiscent of some cigar packets in both design and colour. Each rifle is banded on to a suede-like red backing with the name neatly picked out in gold trim. Thus the container itself makes a neat display case for the model. Construction of each model is a mixture of plastic and metal, very accurately

*Continued on next page*

**Station—from page 519**

also glued two layers of scrap 60 thou thick plastic card at each rear corner to support the platform surface level. I painted the stones at the front edge of the platform grey then painted the top surface to within about 5 mm from the front edge with a light brown mix of poster paint applied fairly thickly to represent earth. I added a lamp (Merit), a seat (Airfix), grass powder and a lichen bush. A sign, and a nameboard for the building are to be added before the model is fully complete.

This perfectly simple structure should be within the capabilities of anyone interested in narrow gauge railways and it gives a very characteristic station for no more than the cost of the Plastikard sheet. Together with the structures given in recent issues, it provides sufficient buildings for a small layout using any of the excellent narrow gauge equipment now on the market. Finally, let it be said that this station, with a higher and longer platform would also be suitable for a standard gauge branch or light railway layout.

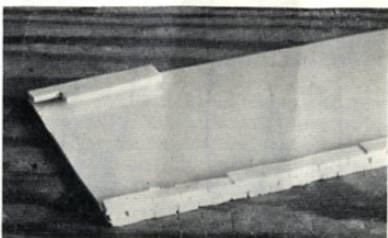

Underside view of the platform under construction showing stone effect.

AIRFIX magazine

**New Books—from page 533**

tively and both enjoy well-deserved reputations as essential and inexpensive reference books for the air enthusiast. Fully up-dated (which in the fast developing world of aviation means considerable revision between editions), they are both 'musts' for the enthusiast who needs to keep abreast of the aviation scene.

**Challenge in the Air.**

Bryan Philpott. Model and Allied Publications Ltd, 13-35 Bridge Street, Hemel Hempstead, Herts. £1.75.

THIS book by Bryan Philpott tells the story of the Air Training Corps and is timed to coincide with the 30th anniversary of the Corps this year. The author, a former cadet and officer in the ATC (and an *Airfix Magazine* contributor), has done an excellent job of condensing a history which covers many aspects of the training of young men for the RAF and Fleet Air Arm during the war and for an interest in aviation during peacetime.

To add interest to a subject which could easily be very boring he has used the experiences of cadets and many of their achievements to tell the story. Many ex-ATC cadets won distinctions during the war, including one VC. Cadets serving in ATC Squadrons were also decorated for heroic action during enemy bombing and since then have a worthy record of rescues, both animal and human.

The early beginnings of the ATC, which can trace a history going back to the first world war, really began with the Air Defence Cadet Corps. Much of this

information is sparsely documented as is some of the wartime events, but the author has nevertheless succeeded in patching together many small news items into a smooth and well-illustrated description. Post-war successes and difficulties are also shown, including some of the present-day activities of the ATC, apart from recruiting potential entrants into full-time service.

As a recruiting medium for the ATC this book could not be bettered. For the present members it will act as a fresher when they read of their proud achievements over the 30 years. Many present-day aircraft modellers can owe their first interest in the hobby to a contact with an ATC unit and for these and the many aviation enthusiasts that this country can now boast, *Challenge in the Air* will take its place amongst other volumes describing how this interest was fostered.

**BUSES**

London Buses. Ian Allan Ltd, Shepperton, Middx. 40p.

LONDONERS, we fancy, will be most interested in this latest edition of a bus spotters' guide which has appeared under various titles over the years. It lists the London bus fleet as currently operating, with full specifications and good pictorial coverage of the various classes. The recent splitting of the old LTB fleet into London Transport and London Country fleets, plus the increasing influx of 'one-man' single- and double-deckers means that there is a lot new in this edition. As always, the book is beautifully compiled and well presented.

**New Kits—continued**

simulating both the colour and the texture of the original. The furnitures are in grained 'varnished' plastic, the barrels, triggers, and other main parts are in gun metal (or something very convincingly like it!), while the bolts and sling swivels are in bright metal. The result is as realistic a set of models as anyone would want. They look as though they would fire but, in fact, the triggers, barrels, and magazines are all solid. However, it is possible to work the bolts in a realistic 'ease springs' movement on most models, and in some cases the bolt can be removed altogether. A colour leaflet with each model gives a bi-lingual factual paragraph on each weapon in the series, though the English version is in the best tradition of comic literal translation. Price of each gun is £1.10, which is not unreasonable in view of the high quality offered.

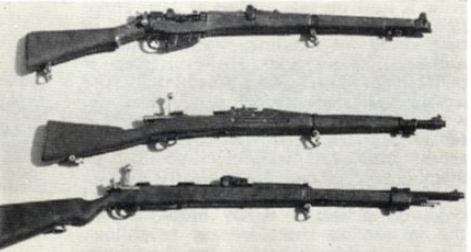

Three rifles from the France Jouets range. Top to bottom are a Lee-Enfield, Springfield M1903 and Mauser M1898.

For those who wish to collect the whole set, France Jouets also make a display stand in the form of a rifle rack. This comes in kit form, in simulated wood finish, and is very easy to put together. This is sold in a presentation pack with the Lebel rifle at £1.75 ready to form the basis of the collection. The rack is of the type familiar in service armouries and the set-up looks most realistic with the guns in place.

The British importers of this France Jouets series is Model-time, 6 St George's Walk, Croydon, Surrey. They can supply by post, but extra should be allowed to cover post and packing. C.O.E.

**Tamiya: 1:35 scale Saladin and Centurion Mk 3**

BRITISH vehicles have received less attention than others in Tamiya's excellent 1:35 scale series of AFV models. However, this is handsomely remedied by the release now of the Saladin and Centurion kits, both of which were announced earlier this year. The Saladin was, in fact, one of the very first Tamiya 1:35 scale kits and the new release is a considerable 're-work' of the original moulds to bring the model up to latest Tamiya standards. From memory of the earlier model, Tamiya seem to have added the silencer, added a commander, touched up the small details, and replaced the earlier tin transmission with a ready-assembled gear train of nylon-type gears. In all a major improvement all round. The other big improvement is in the provision of accurate markings, an excellent transfer sheet providing numbers and formation signs for three

different vehicles. Our advanced sample had only Japanese instructions but British text should be supplied in the main delivery. Even without this, though, assembly is quite easy to follow and this kit is particularly commended for beginners or those who wish to sample 1:35 scale for the first time at relatively modest outlay. Price of the kit is 99p.

The Centurion must undoubtedly rate as a masterpiece of kit production and it ought to be the best selling Tamiya kit in Great Britain. Tamiya obviously did their homework well on this model. We were impressed with an advanced model shown at the Riko trade show earlier this year (see March issue). We misprinted this as a Centurion 8 but it is in fact a Centurion 3. Close inspection of the model shows it to be a modernised Mk 3 as brought up nearly to Mk 5 standard in the middle 1950s. Such detail points as the blanking off plate over the bomb thrower aperture in the turret roof and the auxiliary forward return rollers indicate this. By deleting the turret escape hatch (an easy task) and slightly modifying the turret roof detail it is an easy matter to convert the model to a Mk 5 with 'A' barrel gun. Further small additions, including the fume extractor for the gun, would make it into a 'B' barrel model.

Construction of the model itself is quite straightforward, comparable to the M60A1 reviewed last month. As with the M60A1, the track is in realistic metal colour. All detail is fine and sharp and, as we remarked before, the model captures the essential character of the Centurion right down to the way it sits on its suspension. The kit is highly commended and the only real criticism concerns the instruction sheet which gives some misleading colour scheme information; while the sheet shows two pages of colour schemes on specific vehicles all drawn as Mk 3s, we could only positively identify two of them as actual Mk 3s. The others were Mk 5s, 7s, and 8s, all requiring minor conversion work if the modeller intends to finish the kit as one of these vehicles. The transfer sheet provided is most excellent, with a good selection of alternative markings for the vehicles drawn. Our advanced sample of this kit had the instruction sheet in Japanese only, but an English version will be in production kits which we saw in proof form and can vouchsafe for. The Tamiya Centurion kit is available from Riko stockists, including all mail order suppliers advertising in this magazine. Retail price is £2.50. C.O.E.

**Raretanks: Somua S 35**

THE Somua S 35 is the first release from the Rareplanes stable in a new range which will cover famous tanks, and eventually armoured cars, etc. As a first effort in the AFV field it is an excellent choice, the cast construction of the original being difficult to reproduce as a scratch-built project, and for this reason it deserves to be popular. As a whole, the model is slightly undersized but nevertheless all is well in proportion and this hardly detracts from the appearance of the finished model.

The construction involved no real snags except the running gear and here we found it easier to assemble the complete track, sprocket, idler, etc, as separate units which were attached to the

The parts of the Raretanks' Somua cut out and ready for assembly.

hull complete. The tracks are, of course, the difficult bits and unfortunately one was moulded slightly wider than the other, thus entailing a fair bit of extra work to get them more or less identical. We must stress that they are, as the instructions say, very easily snapped. We would think it easier to scratch build the running gear by a similar method to that advocated by Ken Jones in his article in the April 1969 issue. This used a JS III sprocket, JS III road wheel as idler, Churchill road wheels, and track from a StuG III. The suspension covers from the Raretanks moulding could, of course, be used. For anyone who has a little experience in conversions and scratch building, this model should be easily possible, though it's not for new boys—the only way is to get one and have a go; the parts are there, the rest is up to you and there is a whole new field opening up. G.S.

**Armtec: 1:76 scale AFV accessories**

ARMTEC produce a most useful and well produced range of small accessories of value to AFV modellers in 1:76 scale. The UK distributors are Bellona, Hawthorn Hill, Bracknell, Berks, but the larger mail order suppliers also carry stocks. Already available are such sets as German machine guns and mounts (MG34/MG42), American AFV tools, German AFV tools, and Jerricans. Latest set to reach us is 70 scale (not actual!) feet of tow chain. While intended for miniature tanks this very fine blackened chain (finer even than jewellers' chain) will be of great value to modellers generally. For instance, it makes near scale anchor cable for 1:600 scale warships, rigging chain for Airfix sailing ships, and signal chain for model railways. Highly commended, it costs 19p per length. Our sample came from Jones Bros of Chiswick, who can supply by post, postage extra. C.O.E.

**Bare-Metal: self-adhesive foil**

CLEARLY inspired by Metalskin, another brand of metallic covering foil has now appeared on the market. Known as Bare-Metal, this has rather different properties, being extremely thin, rather like the foil on chocolate bars. The makers claim that this can be applied to a plastic model straight over the surface detail, so that it is not necessary to sand off rivet detail and then re-apply it over the foil. This is made possible, of course, by the very thin nature of the material. As purchased, the foil is held stiff by a thick backing paper in a card-backed folder. We tried our sample on an Otaki 1:144 scale Phantom and can

Continued on page 548



**YOUR INTERNATIONAL MODEL MAIL ORDER HOUSE**

Suppliers to the British and Overseas Governments



★ ★ ★ ★ HISTOREX PLASTIC KIT ★ ★ ★ ★

Historex kits represent at the moment, the foot and mounted troops of the First French Empire.

**INFANTRY FIGURES**

Infantry figures are available in the following ranks: officer, standard bearer, N.C.O., drummer and soldier. Also in any of the following four positions: attention, present arms, marching, attack march. FOOT GRENADIERS OF THE GUARD, FOOT CHASSEURS OF THE GUARD, TIRAILLEUR CHASSEURS, FUSILIER CHASSEUR, FUSILIER GRENADIERS, TIRAILLEUR GRENADIERS, SWISS and DUTCH GRENADIERS, NATIONAL GUARDS OF THE GUARD, GRENADIERS, FUSILIERS, VOLTIGEURS OF THE LINE, FOOT ARTILLERY OF THE GUARD and OF THE LINE, DRAGOONS OF THE LINE, GENDARMES.

**CAVALRY FIGURES**

All mounted figures listed below are available as officers, standard bearers, trumpeters and soldiers. HUSSARS: Revolution: 1805-13, 1813-15. CHASSEURS OF THE GUARD. Full dress or service dress. CHASSEURS OF THE LINE: Centre or Elite Company. HORSE ARTILLERY OF THE GUARD OF THE LINE, MOUNTED GRENADIERS OF THE GUARD, MOUNTED ELITE GENDARMES, HONOUR GUARDS, MOUNTED DRAGOONS OF THE GUARD or OF THE LINE, NAPOLEON 1st and MARSHALS BERTHIER, BESSIERES, MORTIER, DAVOUT, SOULT, GOUVION St. CYR, MURAT and PONIA TOWSKI.

SENIOR AND ASSISTANT STAFF OFFICERS and AIDES de CAMP, CURRASSIERS 1804-15. LANCERS OF THE GUARD and LINE, FRENCH, POLISH and REDLANCERS, CARABINIERS.



**Sanderson 54 mm Figures**

'Roman Slave Market'  
SM3 Customier  
SM1 Auctioneer  
SW1 Girl Standing holding robe  
SW2 Girl dressed in robe from waist downwards  
SW3 Nude Girl kneeling  
SW4 Nude girl sitting  
SW5 Girl sitting wearing robe  
all at 75p each

**LASSET 54 mm FIGURES**

**German Forces Army**

LM1 SS Officer in field service dress  
LM2 SS Infantry in field service dress  
LM3 Panzer Grenadier wearing steel helmet  
LM4 SS Officer wearing leather overcoat and peak cap  
LM5 Infantry in winter dress wearing jacket with hood  
LM6 Panzer crew wearing 'ski' cap  
LM7 Cossack in German Army Dress  
LM8 Afrika Korps Officer  
LM9 Afrika Korps other ranks  
LM11 SS Infantry parade dress

HISTOREX Illustrated Catalogues Standard 10p Extra large 35p

FOOT FIGURES 70p MOUNTED £1.50

**ALMARK PUBLICATIONS**

by Rene North

**REGIMENTS AT WATERLOO**

A superb book by an acknowledged authority on the subject. This is a comprehensive and profusely illustrated reference book which covers all the Anglo-Allied and French regiments involved in the Battle of Waterloo. Gives details of their part in the battle and shows the uniforms in colour, plus about 70 more shown by line drawings or half-tones.

Paperback £1.25 Hardback Bound £1.75

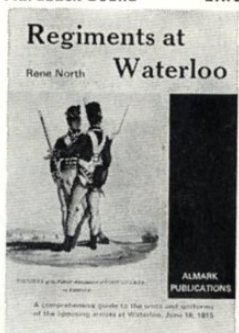

*Exciting world of BOOKS*

- Orders, Medals and Decorations of Britain and Europe £1.75
- Uniforms, Organisations and History of the Waffen 'SS' £4.50
- Flags of the World £2.75
- Naval Swords 1660-1815 £1.50
- Blunderbusses £1.50
- The Pageant of Heraldry £1.25
- Discovering Wargames 25p
- Discovering Militaria 25p
- Discovering Military Traditions 25p
- Head Dresses of the British Army (Cavalry) £1.25
- Head Dresses of the British Army (Yeomanry) £1.60
- War Games £1.05
- Advanced War Games £2.10
- German Field Works of the World War Two 90p



**BELLONA**  
No. 1 Self-propelled Weapons of the German Army 1939-45 43p  
Part 2: Weapons on Foreign-built Fully-tracked Chassis 43p  
No. 2 Semi-tracked Vehicles of the German Army 1939-45:  
Part 1: Prime movers and Self-propelled Carriages 43p  
Part 2: Light Armoured Carriers Sd Kfz 250 43p  
No. 3 Transport used by the British Army 1939-45:  
Part 1: Tank Transporters, Recovery Vehicles and M/c Trucks 43p  
Part 2: Gun Tractors, Bridging Vehicles, Ambulances 43p  
Armoured Vehicles 600 side elevation of Armoured Fighting Vehicles. 43p  
Weapons of the German Infantry 80 photos., 56 pages £1.10  
French Armoured Fighting Vehicles Part 1: Battle Tanks 66p



54 mm MODELS  
Roman Eagle Bearer  
Roman Centurion  
Roman Legionary  
43p each unpainted

- Battles with Model Soldiers £2.75
- Old British Model Soldiers 1893-1819 £1.50
- French Army Regiments and Uniforms £1.50
- Little Wars £1.70
- Introduction to Battle Games £1.05
- Collecting Model Soldiers £1.75
- How To Go Plastic Modelling (2nd edition) £1.50
- How To Go Advanced Plastic Modelling Uniforms and Arms of all Times Volume I and Volume II £2.00
- Uniforms and Arms of 1st Empire Volume I and Volume II £2.00
- Uniforms and Arms of World War One £2.00
- Military Uniforms of the World £1.50

**SHIRE PUBLICATIONS**  
Discovering Battlefields in Northern England and Scotland 22jp  
Discovering Battlefields in Southern England 25p  
Discovering English County Regiments 25p  
Discovering Militaria 25p  
Discovering Military Traditions 25p  
Discovering Model Soldiers 25p  
Discovering Wargames 25p



**Camouflage & Markings Series**  
No. 1 Supermarine Spitfire No. 2 N.A. Mustang  
No. 4 Hawker Tornado Typhoon and Tempest  
No. 5 Gladiator, Gauntlet, Fury, Demon  
No. 6 De Havilland Mosquito  
No. 7 Bristol Blenheim  
No. 8 Boulton Paul Defiant  
No. 9 Bristol Beaufighter  
all 30p each

**OTHER ALMARK BOOKS**

- British Infantry Colours £1.00
- American Civil War Infantry 87jp
- French Napoleonic Artillery 87jp
- British Infantry Regiments £1.00
- German Artillery WW1 87jp
- German Combat Uniforms 1939-45 87jp
- Scottish Regiments 1860-1914 62jp
- Wehrmacht Divisional Signs £1.25
- Soviet Combat Tanks 1935-45 £1.00
- American Armoured Cars 1940-45 62jp
- Sherman Tanks 1941-45 62jp
- Indian Cavalry Regiments 1880-1914 by A. H. Bowling  
A colourful and detailed coverage of the great regiments (like Skinner's Horse) which represented the peak of British imperial achievement. The book has 8 colour plates of uniforms, many line drawings, rare old prints and pictures, and lengthy text. It is similar in format to 'British Infantry Regiments 1660-1914' (already published) but very much longer. An essential reference book for uniform enthusiasts.  
Paperback £1.25 Bound with dustjacket £1.75

Figures by the following:  
GARRISON, OLIVE, LASSET, HISTOREX, STADDEN, HINTON, HUNT, ROSE, MINIATURE FIGURINES

Post and Packing: Please add 10% to all orders up to £5.00, (min. 10p) Over £5.00 post free. C.O.D. Charge 45p

**BMW MODELS, 327-329 HAYDONS ROAD, WIMBLEDON, LONDON, S.W.19 01-540 7333/4**



# photoPAGE

More rare pictures from readers with captions by **Michael J. F. Bowyer**. A free Airfix kit is awarded for every picture published, but please note that there is usually a delay of some months before publication due to the limited space at our disposal.

**Below:** Still flying Lancasters in 1952-53 was 683 Sqn whose TW859 was engaged in map-making flights from Khormaksar, Aden. It is silver overall with white fuselage top and the 'solid' canopy top produced for tropical operations. A somewhat faded squadron badge appears to be painted just behind the nose aerial (D. Pearman).



**Right:** The Firefly FR1 was the mainstay of the Fleet Air Arm in the immediate post-war period when the US Lend-Lease aircraft disappeared. This fine view shows PP580:277/P of No 800 Sqn. PP534 is close by. P is the tail code for HMS Triumph which was in the Mediterranean in the 1945-46 period when this picture was taken. **Below:** Another Firefly FR1 of 800 Sqn, 280/P, noses over on the deck of HMS Triumph during a heavy landing. Spinners and codes appear to be in Sky (Neil Hemlett).



**Above:** Another Firefly FR1, this time aboard HMS Theseus, goes into the catwalk after a heavy landing. Finish is the same as the 800 Sqn machines shown but the codes are differently positioned. Note the underwing roundel at the extreme wingtip and the first two characters of the serial. The spinner is in two colours. At this period (1947) Theseus was in Australian waters (E. M. Meare).



**Above:** A group of No 1 Sqn Spitfire 21s and crews at Tangmere in 1945. An interesting feature is that some aircraft have their serials above the fin flash, eg, LA262:JX-T, LA267:JX-O. In the far distance can be seen JX-N:MK515, a Mk IX. JX-E is LA275, and JX-S has a fin serial. LA227, nearest aircraft on right, also has a fin serial (David Newton).



A standard Harvard II in service with Flying Training Command. Serialled FX257, it was seen at RAF Ouston in 1950. It was silver overall with yellow trainer bands on the fuselage and wings (Eric Taylor).

# Letters to the Editor

## 1815 uniforms

I WOULD question some of the statements made by Robert Gibson in his articles on Anglo-Dutch Artillery (December Airfix Magazine) and Anglo-Dutch Infantry (January):

**Royal Regiment of Artillery (ie, British Foot Artillery):** Their cartridge pouches were white with a brass badge not black.

**Royal Horse Artillery:** Some show uniform (a) some show uniform (b). Mr Gibson seems to have taken a middle path. I don't know which uniform is correct for the Horse Artillery. However Mr Gibson is wrong about the RHA's turban—it was dark blue with yellow stripes.

**71st Highland Light Infantry:** Their facing colour was buff not yellow. Buglers (and probably drummers) did not wear the

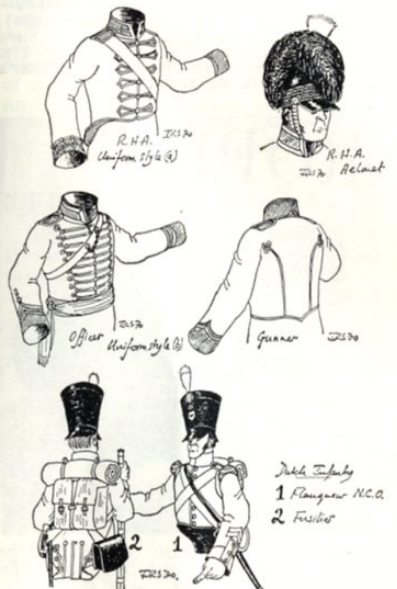

buff coat after 1811-12. Officers had chain shoulder straps and wings.

**Dutch Belgian Infantry:** I don't know where Mr Gibson obtained his information about Dutch-Belgian Infantry but he seems sadly misinformed. Their coats were single breasted and blue but they had no lace across the breast. From the beginning of 1815 all cuffs and collars and piping were white for line infantry. The lining of the coat was red. There were two 'Flaugueir' companies—elite companies—one light and one heavy. The Heavy Company in Dutch battalions had a white plume with a red top and blue and white rolls on the shoulders. The light company were the same but for a green tip on the plume.

Belgian flaugueirs had green cords and pom-poms or red cords and pom-poms. Fusiliers had white cords and a smaller white pom-pom. There were 36 battalions not 16 battalions as Mr Gibson would have

Letters to the Editor selected for publication entitle the senders to each receive a free Airfix plastic construction kit of their choice. We are always pleased to receive your comments and pictures, which will be considered for publication. Submitted material and pictures can only be returned if accompanied by a stamped addressed envelope, and the Editor cannot accept responsibility for safe keeping of any such contributions, neither does he necessarily agree with comments expressed by correspondents in the letters column. Please note that any letters anticipating a reply MUST be accompanied by a SAE or stamp.

it. There were 4 Belgian Line battalions (Nos 1, 2, 4 and 7) and 2 Belgian Jager battalions (Nos 35 and 36). There were 8 Dutch Line battalions (Nos 3, 6, 8, 9, 12, 13, 14 and 15) and 4 Jager battalions (Nos 16, 17, 18 and 27). The remaining battalions were Swiss and Colonial regiments. In addition there was the 28th Infantry Regiment Orange Massan and the 2nd Light Infantry Regiment Massan (this regiment was not numbered in the line).

I may be wrong on this but I understood that Brunswick infantry wore the Polrock—a waisted black ¾ length coat similar to the garment worn by Prussian Landwehr cavalry.

**I. Scott, Chippenham, Wilts.**  
Robert Gibson writes: *The Polrock was worn in Spain. The uniform described was introduced in 1815 prior to Waterloo—for verification see the painting of the death of the Duke of Brunswick in Caravel Book's 'The Battle of Waterloo'. Officers sometimes wore the Polrock (or Litewka) even in 1815, but not by regulation.*

Mr Scott also made the point that Dutch-Belgian Infantry did not all have lace across the breast of the tunic. The Royal army was in a period of transition with regard to uniform at this time, and both variants occurred. He also sent sketches which illustrate the 'other' tunic, which was piped in white. It is worth pointing out that some small detail points have to be generalized in this series for space reasons. As a general rule I cover the details which are practicable for 20 mm (OO/HO) figures.

## Airmodels hints

FROM personal experience with the Airmodels conversion kits (specifically the Do 17P-1) and from reading articles on conversions by others, one of the chief problems is the lack of area for attachment between the new section and the old fuselage or wing. Quite by accident while working on the Do 17P-1, I removed too much of the fuselage, so that when the new forward section was added, the wings would not fit properly. Since I fitted the pieces together without gluing, there was no problem taking them apart. The clearance needed for the wings was very slight. From a pack of plastic card sheets I selected one sheet, placed the cut end of the fuselage on it, and traced the outline on the sheet. The outline was followed with an X-acto knife and a plastic bulkhead resulted. The bulkhead was fitted to the fuselage (after the fuselage was evened).

Then the new forward fuselage was assembled and allowed to dry. The rear section of the new fuselage was sanded flat (it was slightly rounded). The forward fuselage was then joined to the bulkhead. The large area of the bulkhead and the new fuselage allowed a very strong bond to be formed.

That is a very long drawn out explanation, but the point I wish to make is the value of the bulkhead. A plastic section will attach easier to a plastic fuselage. When the bulkhead is inserted perpendicular to the fuselage, the large surface provides much easier attachment for a wooden section. With a good epoxy the new section should be virtually inseparable from the original fuselage. Instead of having only the thin sides of the fuselage for attachment, you have the area of a fuselage cross-section. If you are using a balsa block, it would be ideal.

The bulkhead should also offer the advantages of making a fuselage or wing an exact scale length. This should be easy by cutting the section and inserting the desired thickness of plastic sheet or by laminating sheets to the desired thickness. After sanding and filling, there should be no evidence that the kit was altered.

Thank you for publishing a really first class magazine; keep up the good work.

**Michael O. Lebak, Captain, USAF,**  
OSI Det 6295, RAF Bentwaters,  
Suffolk IP12 2RQ.

## Transfer tips

AS a tip to readers who may be working with older kit transfers (decals), a few drops of white casein glue (Elmer's or Koll) dissolved in the soaking bath aids immeasurably in really making them stick. An additional one or two drops of household ammonia in the same solution will clarify the yellow haze that sometimes accompanies these older transfers, as well as making them much more flexible.

Another handy item recently available to hobbyists is the peel-off, rubber-based eye shadow makeup for milady, which makes wonderful masking paint for canopies, chrome, camouflage patterns, etc.

Thanks again for your great magazine, and I hope these hints might help a builder who is having a finishing problem.

**Robert Hutchison, US Army, Europe.**

## German Harvards

IN YOUR issue of April 1971 on page 427 there is a photograph of a Harvard in German markings. The comment with this states that no Harvards ever appeared in German markings. This is quite incorrect.

The Luftwaffe captured a number of L'Armee de L'Air Harvards and pressed them into service. These are illustrated on page 155 *Dora Kurfurst und Rote 13* prior to the application of Luftwaffe markings, and page 19 Vol 1 after application of Luftwaffe markings at A/B116 Goppingen November 1941.

The post-war Luftwaffe also used Canadair Harvard IVs and an illustration of these may be found on page 125 of *The Air Forces of the World* (W. Green and J.

*Continued on next page*

## Letters—continued

Fricker, Macdonald 1958) at Flugzeugführerschule 'A' Landsberg.

I should also like to draw attention to Bruce Robertson's detail of 207 Sqn Handley Page 0/400s. In his article he states that B flight colours were possibly blue and C Flight possibly yellow. He then goes on to state that the normal flight colours were A flight—red, B flight—blue, and C flight—yellow. In my air-force experience A flight was red, B flight yellow, and C flight blue, D flight green. However, I appreciate that there are always anomalies, and as Mr Robertson states in his article, the actual case in question of 207 flight colours can only be solved by an ex-207 Sqn member.

C. M. Rice, Lympstone, Devon.

Several other readers made the very pertinent point about the captured German Harvards. We must admit we overlooked these and were thinking in the context of 'bogus' colour schemes like that illustrated (and often seen on Harvards in films), rather than actual service machines.—Editor.

## Model Trucks

MY THANKS to Dennis Harnaman for his letter (March issue). I agree the Guy FBAX should of course have a well type body, but this, and the other vehicles, were only meant, as I mentioned, as simple conversions suitable for wargames, etc. The Matador body was used for its strength and has stood up well to constant handling and I thought this slight variation from true scale worthwhile for this purpose. The flat floor does also simplify the carrying of 'troops'.

Gerald Scarborough, Nr Sleaford, Lincs.

## Flotilla markings

WHEN Peter Hodges was describing the modelling of a 'Hunt' class destroyer he did not include a variant of the Type 1. This included the removal of one set of twin 4 inch guns and the emplacement of a 2 lb bow chaser. This was done because of lack of stability.

This was remedied in type II's by 2½ inches more beam. The bow chaser was then removed and the twin 4 inch reinstated.

The system of funnel markings introduced in 1925 was as follows: Flotilla leaders wore a 4 ft deep band at the top of the fore funnel. Divisional leaders had a 2 ft band—black for Mediterranean Fleet, white for Home Fleet—3 ft below the top of the fore funnel. 2 ft deep Flotilla markings were painted 3 ft below the top of the after funnel as follows:

- 1st Flotilla (Med) 1 black
- 2nd Flotilla (Med) 2 black
- 3rd Flotilla (Med) 3 black
- 4th Flotilla (Med) Nil
- 5th Flotilla (Home) 1 white
- 6th Flotilla (Home) 2 white

In 1935 the 2nd Destroyer Flotilla marking was altered to one red band. Added then was the 8th Destroyer Flotilla, one black over one white band. In 1937 the 2nd Flotilla was changed to 2 red bands and the 4th Flotilla became Home Fleet. The next year the three Home Fleet Flotillas, 4th, 5th and 6th, adopted 1, 2, and 3 white bands respectively.

In 1939 owing to the introduction of single stack destroyers the system was again changed. Single stacked Flotilla

548

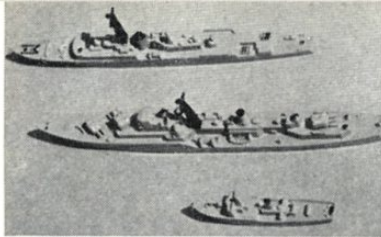

Model Figures & Hobbies, 8 College Square North, Belfast, are now selling the last of the discontinued line of Triang ships which are neatly cast 1:1200 scale replicas, ideal for naval wargames. Ready painted, they lend themselves to added detailing and repainting and can be made into quite exquisite models. Our picture shows a Type 15 frigate, 'Daring', and 'Ton' class mine-sweeper. The first two cost 12½p each, and the last is 7½p. Other types are available.

leaders carried a 3 ft band over the Flotilla bands and Divisional leaders had a 2 ft vertical band the same colour as the Flotilla bands and extending 6 ft below it.

The entire system changed to:

- 1st Flotilla (Med) 1 red ('G' Class)
  - 2nd Flotilla (Med) 2 red ('H' Class)
  - 3rd Flotilla (Med) nil ('I' Class)
  - 4th Flotilla (Med) nil ('Tribal' Class)
  - 5th Flotilla (Med) 1 black ('K' Class)
  - 6th Flotilla (Home) 1 white ('Tribal' Class)
  - 7th Flotilla (Home) 2 white ('J' Class)
  - 8th Flotilla (Home) 3 white ('F' Class)
  - 9th Flotilla (Home) 1 black over 2 white ('V' and 'W' Classes)
  - 17th Flotilla (Reserve) 1 red over 2 white ('V' Class)
  - 19th Flotilla (Reserve) 1 white over 1 black ('V' and 'W' Class)
  - 20th Flotilla (China) 1 white over 1 red ('D' Class)
- A. Banner, St Brelade, Jersey.

## French Artillery

NOTE with dismay the letter from Keith Millard, Luton, on the recently released Airfix 20 mm French Artillery.

I have done considerable research over the years on the subject of French Napoleonic Artillery and I cannot cite any instance of a surtout, as the single breasted garment was called, being commonly worn. The dress shown by Airfix is the habit veste, introduced in 1812, and is perfectly correct.

Regarding the epaulettes, I agree that regulations specified shoulder straps but as I point out in my recent book on the subject this regulation was ignored by many units and red epaulettes were worn.

I trust this letter may clear Airfix of the suspicion of inaccuracy.

Michael G. Head, Paignton, Devon.

## Launcher Tubes

CHRIS ROGERS in his article on the C T34 Calliope (March issue), suggests that the rocket tubes can be made of cocktail sticks, cut to size. His sticks were too large in diameter for complete accuracy, but only slightly, so he used the new plastic rod from Jones and Bros.

I have found that Deeko cocktail sticks are the diameter required and make very good tubes. They can be purchased almost anywhere for 6p a hundred.

K. W. Moor, Wallasey, Cheshire.

## BRITISH MODEL SOLDIER SOCIETY

ON Saturday, April 24, 1971, the BMSS held its Annual Competitions at Caxton Hall, Caxton Street, SW1. The occasion was extremely well attended by members from branches all over the country.

Over 250 entries covering all periods of history competed in the various classes, the standard of every item being high, some of them achieving an almost miraculous realism, whilst the diorama sections produced a great variety of ingenious representations of scenery and terrain.

Most noteworthy was the way in which techniques both of modelling and painting had improved out of all recognition over the past decade. Novices are now producing work of which seasoned and skilled modellers of a year or so ago would not have been ashamed. Younger members too made a considerable contribution to the list of entries, achieving standards which auger extremely well for the future success of the Society.

Before presentation of the trophies, the President, Roy Dilley, emphasised the essential unity of the Society as exemplified by the magnificent support given by all branches in contributing to a really first-class display. The President's wife, Mrs Wendy Dilley, presented the trophies, aided by Mrs Jane Clayton, wife of the late Secretary of the Society.

Among prizewinners were D. Pitt (Britain's Trophy), J. V. Smith (Lockwood Trophy—Officer of Life Guards Camel Detachment), P. Wilcox (Gottstein Cup—Byzantine Field Officer), E. Suren (Nicholson Trophy—21st Lancers at Omdurman), D. Skinner (Winter's Trophy—Roger's Rangers).

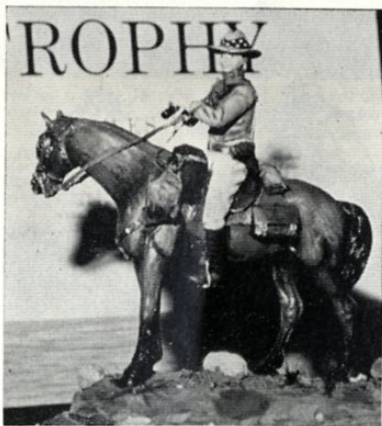

D. Pitt won the Anzac Trophy at the BMSS Competitions with this fine model of a Matabeleland Mounted Policeman, 1896.

## New Kits—from p. 544

confirm how well the surface detail of the plastic shows through the foil—our knife slipped and scratched the wing surface very slightly but the scratch was faithfully reproduced through the covering! The makers stress that the plastic surface must be perfectly clean before application as even particles of dust will show through.

Bare-Metal is made in USA by Bare-Metal Foil Co, 19419 Ingram, Livonia, Michigan 48152, price \$1. The sole UK distributor is D. S. Ives, 104 Longwood Gardens, Clayhall, Ilford, Essex, and the UK price is very reasonable at 45p post free. One sheet should suffice for the average 1:72 scale fighter. C.O.E.

AIRFIX magazine

## 'River' Class—from page 515

In the 'River' class it was mounted on what would otherwise have been 'A' gun position and a weather and splinter-proof shield was fitted abaft the mounting carrying circuit switches, a training receiving and a training handwheel. The input pointer on the training receiver moved for a combination of ship roll and deflection (or 'aim-off'), and the mounting trainer, in matching pointers, tilted the mounting accordingly. Normally, the ship was steered on the correct attack course to keep the deflection angle to a minimum because aim-off tended to distort the pattern of the bomb trajectory. In the final development of the mounting, the training and drive arrangements were adapted for Remote Power Control and were then fully automatic.

The Hedgehog crew was eight, which included three loading numbers, and in the 'Rivers' a sloping canopy projecting downwards from the forward 4 inch gundeck gave them protection from the weather. Large ready-use ammunition lockers flanked this area in which at least two complete salvoes could be stowed.

Among the cluster of indicator and repeat instruments on the bridge was a Master three-position switch. Its central position was 'off' each side of which was a position either for Hedgehog or Depth Charge. This selected the firing and control circuits for the particular form of engagement, because whereas the ten pattern D/C attack was carried out at comparatively high speed, the Ahead Attack was a creeping affair.

The natural successor to the Hedgehog bomb and Depth Charge was the Squid Bomb, which was fired by an ahead throwing weapon but had a preset depth fuse and the destruction power of a depth charge. However, the Squid, as a weapon, was only fitted in HMS *Helmsdale*, and as this was for post-war development, it is really out of context in the present article. It did appear in other classes, however, before the end of the war.

## H/F Direction Finding Aerials

Although not a weapon in the true sense of the word, the H/F-D/F can be included here, because of its importance as a submarine detection device.

Once merchant ships had been sighted by a patrolling U-Boat, it usually surfaced to shadow the convoy and communicated by H/F radio with other submarines in the area as well as to U-Boat HQ ashore. In this way the Wolf Pack mustered its forces.

Unknown to the enemy, however, the H/F-D/F set had been developed, and while it could not on its own pinpoint a U-Boat on the surface by picking up her radio signals, two escorts so equipped and operating in unison were able to do so (by a cross-bearing 'fix'), thereby giving all in company advance warning of an impending assault.

Those escorts with a 'sprint speed'—like the 'Hunt' class and the converted escort destroyers—were also able to deliver attacks ahead of the convoy by this means, frequently catching unwary submarines on the surface.

## Hull and Superstructure Features

All 'River' class ships had a tripod foremast, crossed by a single yard with a conventional look-out position arranged at the intersection of the tripod 'legs'. A diminutive main mast rose from the athwartships Oerlikon gundeck, and had a small yard and monkey-gaff for the ensign.

There was no Fire Control Director on the bridge, but instead, a Surface Warning Radar, mounted on a lattice pylon. The early 'lantern' was the most usual fitting, but later units had the more versatile Type 277 (similar to part 29 in the Airfix *Devonshire* kit). This could elevate as well as train, and therefore could also serve as an Air Warning. Otherwise a separate Air Warning Aerial was mounted on the fore topmast.

Amidships, the boats were contained in radial davits pivoting in brackets extending from the ship's side. There was sufficient space to allow the davits to be stowed more or less fore-and-aft rather than directly inboard, allowing for reasonably rapid lowering of the boats. A 27 ft whaler was carried to port, balanced by a 25 ft motorboat to starboard with a dinghy immediately abaft it.

The quarterdeck area was mostly taken up by the long depth charge rails leading to the stern traps, and four depth charge throwers with their associated ready use stowages. Some 20 ships were fitted for mine-sweeping duties, and had heavy-duty davits for the sweep paravanes on the extremity of each quarter. They were never, in fact, used in a minesweeping role—indeed, many minesweepers were used as escorts—and a few of the 'Rivers' had extra depth charge throwers in addition to the standard four.

So much, then, for the 'River' class frigates and their equipment. The second part of this article will detail the construction of an example of these fine little ships, using a modified Airfix 'Hotspur' hull.

## New Kits from Airfix

THE latest Airfix construction kit is the Chieftain tank, and like all other Airfix fighting vehicles it is made to 1:76 scale. The completed model with its 120 mm high velocity gun in the forward firing position measures 5½ inches long. As the main battle tank of the British Army, the Chieftain has heavy and well-sloped armour plus formidable armament. The Airfix kit accurately reproduces the full hull detail such as air cooler louvres, lights, driver's hatch, searchlight, machine guns and numerous other items of ancillary equipment. The characteristic 'lagging' on the gun barrel is also reproduced. The completed model is supplied with painting instructions and appropriate British Army transfers. It costs 24p.

The latest addition to the Airfix range of OO/HO rail models is a superb kit of the British Railways Mogul. No less than 115 of these locomotives were built at Harwich and Doncaster, and were in service on all regions except the Western. The Airfix model embodies all the detail and moveable features of the actual locomotive and has been designed to fit on standard OO and HO tracks (16.5 mm). The parts have been produced in black polystyrene to create realism and the driving wheels and pony wheels are moveable. The driver's cab contains a wealth of detail including pressure and brake gauges, speedometer, firebox door and ancillary equipment. The Mogul, which was first introduced in 1952, was used extensively until the advent of diesel traction on British Railways and the low axle loading of under 17 tons gave this particular class wide route availability. The Mogul kit costs 50p and comes complete with transfers.

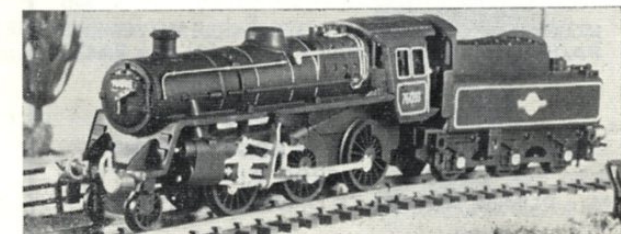

June, 1971

549

# BELLONA

## Battle Game Scenery and Landscape Features

- ★ The Number One Range of Models for all Battle-games—30 super detail sets to choose from all to 1/72 scale.
- ★ Many of these will combine together to make bigger and better Battlefields.
- ★ Diorama range can also be used as individual set pieces.
- ★ Most items formed in tough desert sand coloured P.V.C. which is easy to paint if you wish. This attractive basic colour blends well with matt brown and greens etc to make most realistic settings for your Minitanks, Airfix Military Vehicles and soldiers etc.
- ★ Additional features on some sets include removable pillbox, trench and bunker roofs.

Defence works and Landscape Features **Price 17½p**  
Large Diorama Fortification Sets **Price 57½p**

## BELLONA

FIRST IN THE FIELD AND STILL THE BEST

Now made by MICRO-MOLD PLASTICS  
1 Unifax, Goring-by-Sea, Sussex. Tel: Worthing 46999  
Send S.A.E. for illustrated list.

## PROTAR MODEL MOTORCYCLES FANTASTIC DETAIL

HONDA 250 cc 6 Cylinder	£3.45
M.Z. 250 cc Twin Cylinder	£3.45
SUZUKI 125 cc Twin Cylinder	£3.45
YAMAHA 250 cc 4 Cylinder	£3.65
BENELLI 350 cc 4 Cylinder	£3.25
BMW 500 cc SIDECAR RENNESPORT	£3.95
M.V. 3 Cylinder 500 cc	£3.65
NORTON 500 cc MANX	£3.25
MODEL CASES	70p

AND MANY MORE

## BAYONET WARGAME PUBLICATIONS

NAPOLEONIC WARGAME RULES	25p
AMERICAN CIVIL WARGAME RULES	30p
WORLD WAR TWO WARGAME RULES	40p
WORLD WAR ONE WARGAME RULES	30p
MOVEMENT ORDER PADS, OFF TABLE MOVEMENT PADS, STANDING ORDER PADS—ALL 25p EACH	

## HOBBY CRAFTS

28 HAWLEY STREET, MARGATE, KENT  
LATEST: REVELL, FROG, AIRFIX, ETC.  
PLEASE ADD 15p TO ORDERS FOR P. & P.

I do not claim to have the largest stocks but I do have the best display models. Come and see how they should be put together, and perhaps I can sell you some of the following items. Plasticard, Battle Grounds, Historex, Bellona Prints, Profiles, all makes of plastic kits, also large selection of books.

## MODEL SUPPLIES

D. Bryant  
328 Brockley Road, London, S.E.4  
Tel: 6926292

## HISTOREX FIGURES

We carry a wide selection of the Historex plastic Napoleonic French figures, including Cavalry, Artillery, Sappers, Bandsmen, etc.  
Napoleon & Josephine in Coronation Robes **£1.50**  
Duc de Lauzun Mounted **£1.50**  
Murat Grand-Duc de Berg **70p**

New HISTOREX Catalogue 35p post 5p

## H. A. BLUNT & SONS LTD

Mill Hill Circus **38 Fretherne Road**  
London NW7 4RN **Welwyn Garden City**  
Phone 01-959 2877 **Herts. Phone 26884**

## AIRFIX MAGAZINE— Back Numbers

The following issues are still available:

1969: **March**—Sherman BARV. **April**—Sopwith Pup and Mk V tanks. **June**—Danish Catalinas and panzer uniforms. **July**—'Battle' class destroyers. **August**—Fairey Fulmar conversion and JS3 details. **September**—Avro Manchester conversion. **October**—'Flower' class corvettes and Ventura conversion. **November**—Sandringham and O-Z class destroyers. **December**—Grant and Dakota conversions. 1970: All issues from June to December inclusive.

Back copies cost 18p each, including postage (23p from November 1970 issue onwards). Please address all requests for back copies, together with your remittance, to our circulation department at SURRIDGE DAWSON & CO. (PRODUCTIONS) LTD, PUBLISHING DEPT, 136 NEW KENT ROAD, LONDON SE1.

## DID YOU KNOW...

That the readership of Airfix Magazine has increased by nearly 35 per cent in the last two years.....

That over 40,000 copies were printed last month and that an average of 2½ people read each copy (which means our readership is now approximately 100,000 per issue).....

That Airfix Magazine advertising is the most effective and economical way of promoting and selling plastic model and hobby services and products throughout the country.....

ADVERTISEMENTS BRING RESULTS — JUST TRY IT!



## Win a FREE 7 day trip to America by BOAC VC10

Part 1 closes June 19th

**SO ACT NOW AND POST YOUR ENTRY FORM TODAY**

If you didn't enter the first part of the JET-AWAY CONTEST why not enter part 2? Ask at your usual Store, Model Shop or branch of W. H. Smith for the full details and entry form that could be your passport to America. Simply 'stamp' it with the Jet-Away Stars now being given free with Revell Model Kits, then try your skill at the 'so easy competition', and this Autumn you could be skyborne on a fabulous BOAC VC10 trans-Atlantic jet for an action packed trip to California.

**PLUS** another 100 runners-up prizes of Revell Kit Vouchers worth £2 each.



REVELL (G.B.) LTD., CRANBORNE ROAD, POTTERS BAR, HERTS.



Get your Jet-Away Stars with any Revell kit, like this superb Porsche 911



## New from Profile



**224 Supermarine Walrus and Seagull variants**  
The 'shagbat' as it was affectionately known in service slang, served both the RAF and the FAA in many theatres and guises.



**11 The Norris Locomotives**  
The first US locomotives to be exported. Norris's design influence in Europe only second to Stephenson.



**25 Cromwell and Comet**  
Two famous British cruiser tanks. Both saw action in WW2. This Profile follows the action from the desert to the Rhine.



**6 Kriegsmarine Prinz Eugen**  
Famous German WW2 heavy cruiser. Participated in some of the most dramatic sea actions of the war.

**Profile Publications Limited**  
Coburg House Sheet Street Windsor Berkshire Tel Windsor 69777

## VISIT THE MODELLERS MECCA OF LANCASHIRE

**PLASTIC KITS**  
We estimate that we have over 1,500 kits to choose from. Prices from 14½p to £6.99.

**AERO MODELLING**—Kits by top manufacturers.  
**BOATS**—Fibre Glass boats.

**TRAINS**  
Including all accessories. Scenic layouts made to order.

**ACCESSORIES**  
Including dopes, paints, authentic paints, enamels, cement, Micro balsa wood, marine fittings, Ripmax, etc. Airfix painting by numbers in stock. Large selection of engines.

Mail order welcome—personal payment plan available.

### TONY'S MODEL CENTRE

10 Chapel Street, Pemberton, Wigan. Wigan 83208

## MINIATURE FIGURINES LTD.

Telephones Southampton 20855 West End 4651 (after 7 pm)

LARGEST RANGE OF HIGH-QUALITY METAL WAR-GAMES FIGURES AVAILABLE TODAY

CATALOGUE 18p. HOUSE MAGAZINE 15p.  
INFANTRY 8 for 50p. CAVALRY 3 for 50p.

TRADE ENQUIRIES WELCOME

**5 NORTHAM ROAD, SOUTHAMPTON**  
**SO2 0NZ**

**Modeling • Data • Photos**  
**War Gaming • Drawings**  
**History & Articles**

**A MONTHLY MAGAZINE FOR ARMOUR BUFFS**

Every month 'AFV-G2' brings you 30 pages of scale drawings (1/32, 1/48 and HO), photographs and accurate historical information on armoured vehicles and formations. Complete data for war-gamers and modelers... **Write for Information!**

**NORTH AMERICA:**  
AFV-G2 (DEPT. A)  
P.O. BOX 293  
LA PUENTE, CALIF. 91747 U.S.A.  
\$6 a year... sample 60¢

**UNITED KINGDOM:**  
GREENING  
KNOLL COTTAGE  
KNOLL ROAD  
DORKING, SURREY  
£3 per year... sample 30p (G5)

FOR THE BEST IN VACU-FORMED KITS  
**READY NOW—**  
**THE WESTLAND-HILL**  
**PTERODACTYL Mk.1**

**AF AIRFRAME**

THIS INTERESTING KIT FOR THE TAILLESS BRITISH AIRCRAFT OF THE 1920's, FEATURES THE AIRFRAME CONSTRUCTION METHOD TO SIMPLIFY BUILDING

£1.50 Plus 25p postage  
J. TARVIN  
5166 PORTLAND STREET  
BURNABY 1  
BRITISH COLUMBIA  
CANADA

Write for list of other kits available

# HOBBY LOBBY LTD

<p><b>ARMOUR VEHICLES all at 17p</b> Churchill Russian T34 Sherman 1916 Mk. I Stalin Tiger Matador 5.5 Gun Panther Postage 3p</p> <p>Tank Transporter 24p Centurion Mk 8 24p LCM Sherman 34p 88 mm Gun Tractor 24p RAF Emergency Set 24p RAF Refuelling Set 34p Postage 5p</p> <p><b>AIRCRAFT 1/72 all at 17p</b> Me BF 109 G Junkers 87 Bristol Bulldog Russian Yak Henschell HS 123 Hurricane IV Typhoon Airacobra Hawker P1127 Chipmunk Mustang P51D Tiger-Moth Gladiator Mk I Corsair Fockler D.R.I Folland Gnat Postage 3p</p> <p><b>AIRCRAFT 1/72 all at 24p</b> Me BF 110-D Mosquito Hawker Hunter Firefly Mk 5 E.E. Lightning Dauntless Starfighter MiG 21 Fairley Battle Henschell 129 Grumman Duck Devastator Postage 5p</p> <p><b>AIRCRAFT 1/72 all at 34p</b> Junkers Ju 88 Focke Wulf Meteor Lockheed Hudson NA39 Buccaneer Boston Dornier 217 Blohm-Voss</p>	<p><b>AIRFIX Sea-King</b> Phantom F4B Boston Bristol 192 Jetstream Lunar Module Postage 7p</p> <p><b>AIRCRAFT 1/72 all at 50p</b> Heinkel III Wellington Rotodyne B25 Mitchell S.M. 79 Mk I Black Widow Ford Tri-Motor Hampden F111A Illyushin Postage 9p</p> <p><b>AIRCRAFT 1/72 all at 65p</b> Halifax Flying Fortress Catalina Lancaster Heinkel 177 Junker Ju52 Postage 10p</p> <p><b>AIRCRAFT 1/72 85p</b> Short Stirling B29 Super Fortress £1.05 Lockheed Tristar £1.85 Boeing 747 Jumbo £1.23 Lockheed C130K Hercules £1.23 Postage 10p</p> <p>SRN4 Hovercraft £1.35 1971 Catalogue 22p post paid</p> <p><b>AIRCRAFT 1/72 all at 19p</b> Mustang Spad XIII Hawker Tempest Sopwith Camel Kawasaki Hien Albatross DIII Curtiss Kittyhawk Nieuport 17c ME-262 Fokker DVII Corsair SE-5a Brewster Buffalo DH 11 Grumman Morane Saulnier</p>	<p><b>REVELL</b> Airacobra Fokker Eindecker PZL P-11c Nieuport 28 Fiat CR 42 Sopwith Triplane Boeing Kaydet Spitfire Mk II Boeing P-26A ME-109 Macchi MC.200 Thunderbolt Curtiss Hawk Focke-Wulf 190 Hawker Hurricane Zero Postage 3p</p> <p><b>AIRCRAFT 1/72 all at 49p</b> Corsair 11 Phantom Vigilante Marauder Stiletto Heinkel Jolly Green Giant Ju 88 Bronco Corsair Hughes Cayuse Havoc SAS Caravelle Navy Phantom Sikorsky Delta Dagger Air Sea Rescue S.A.A.B. Douglas DC-9 Martin B-57B Postage 7p</p> <p><b>AIRCRAFT 1/72 all at 77p</b> Swing Wing Flying Fortress Lady Luck Dambuster R.A.A.F. F111 Liberator Catalina Focke-Wulf Lockheed SR71 Patrol Bomber Skycrane Lancaster Mk I DC-8 Postage 8p</p> <p><b>AIRCRAFT 1/28 and 1/32 all at 89p</b> Spitfire Mk I Spad Curtiss P-40E Sopwith Me 109F Fokker Seafire Zero P-51 Mustang Aleutian Tiger Wildcat Me 109G 'Gustav' Postage 10p</p>	<p><b>REVELL</b> Sullivans Prinz Eugen P.T. 207 Massachusetts Sports Fisher Pennsylvania P.Y. 212 Alabama Postage 5p</p> <p><b>SHIPS 77p</b> North Carolina USS Washington Tugboat Forrest Sherman Benledi Longbeach Bismark Boston Tirpitz Franklin Russian Spy Ship Essex Trawler</p> <p><b>SMALL GALLEONS £1.1-</b> Golden Hind Constitution Bounty Santa Maria Mayflower Charles Morgan Beagle Victory Postage 10p</p> <p><b>MOTORCYCLES £9.95</b> Yamaha Scrambler Triumph Drag Yamaha 350 Honda Super Yamaha Dirt Bike Sports Kawasaki Mach 111 Honda Racing Bike Triumph Custom Honda Drag Triumph Tiger Honda Scrambler Postage 10p</p> <p><b>MOTORCYCLES £3.80</b> Triumphant Trike Harley Police Bike Electraglide Harley Hog Postage 10p</p> <p><b>TAMIYA FULL RANGE MINI-TANKS</b> FULL RANGE MANUAL 70p post paid TRANSFERS BY: RIKO, ALMARK, DRI-DEC, FULL RANGE</p>
--	---	--	--

VISIT THE FINEST SELF-SERVICE MODEL SHOP IN THE SOUTH!  
**52 COMMERCIAL ROAD, SOUTHAMPTON**  
TELEPHONE: 25919

## S.W. Scotland's only Model Shop!

ALL THE LATEST!!

AIRFIX — REVELL  
FROG — TAMIYA  
BANDAI — NICHIMO

MINI-TANKS — BRITAIN'S MODELS  
TRIX N AND OO GAUGE RAILWAYS

★ MAIL ORDER ★

UP TO 50p, 5p UP TO £3, 20p  
UP TO £1, 10p UP TO £4, 25p  
UP TO £2, 15p OVER £5 FREE

**THE MODEL SHOP**  
6 QUEEN STREET  
DUMFRIES

## NELSON LANCASHIRE

For Plastics, Railways, Aircraft, Boats, Cars, etc.  
Open 9.30am till 6pm (5.30 Saturdays). Closed all day Tuesday (appointments only). Call or post.  
We have Standing Orders for all Airfix, Revell, Frog new releases. Other makes as available.

**THE MODEL SHOP (NELSON) LTD**  
57 Railway Street, Nelson  
Tel: Nelson (0282) 65591

## RUSS

101 Battersea Rise, London, S.W.11  
LARGE STOCKS OF PLASTIC KITS  
BY LEADING MANUFACTURERS

INCLUDING  
Airfix Frog Tamiya Revell  
Radio controlled model aircraft and boats  
Late night opening 7 o'clock Fridays  
01-228 6319

## EVERYTHING FOR PLASTIC MODELLERS

STOP PRESS!

**FROG HORNET 1/72 KIT 26p.**

**AIRCRAFT**  
OUR OWN 1/72 German W.W.1 Transfers 7p sheet.  
NEW! FROG FOCKE WULFE Ta 152 Kit 19p.  
NEW! RIKO CESSNA SKYHAWK 1/35 Kit £1.25.  
NEW! REVELL HURRICANE 1/32 Kit £1.05.

**ARMOUR**  
NEW! TAMIYA KUBELWAGEN 1/35 Kit 65p.  
NEW! TAMIYA British 6 pdr. Anti-Tank Gun 65p.  
NEW! BANDAI JEEP and TRAILER 1/32 Kit £1.25.  
NEW! OTAKI PANZER 3 1/35 Kit £1.30.  
NEW! BANDAI PANZER IV G 1/30 Kit £2.25.  
NEW! BANDAI HEUSCHRECKE 1/30 Kit £2.25.

**CARS AND BIKES**  
NEW! TAMIYA HONDA CB750 1/6 Kit £7.99.  
NEW! FROG Bentley, Mercedes or Alfa Romeo Kits £1.

**SHIPS**  
HELLER JEAN BART Battleship Kit £3.99.  
HELLER RICHELIEU Battleship Kit £3.99.  
Latest ALMARK Transfers and Books  
We stock DRI-DEC  
PLEASE ADD POSTAGE TO ALL ORDERS  
CATALOGUES: Airfix 22p, Revell 15p, Aurora 18p, Frog 10p,  
Slaters 15p, etc. All post paid

**JONES BROS. OF CHISWICK**  
56 Turnham Green Terrace, Chiswick, W.4  
Tel. 01-994 0858 Est. 1911  
Closed all-day Thursday Member I.P.M.S.

# PSL BOOKS FOR MODELLERS

## A great new series for ship modellers



### HMS VICTORY

No 1—Classic Ships, Their History and How To Model Them

By Noel C. L. Hackney  
 'HMS Victory', published in association with Airfix Products Ltd, not only describes the history of the vessel, but also how to model it accurately from the Airfix Classic Ship kit. Noel Hackney, an expert ship modeller and contributor to 'Airfix Magazine', gives comprehensive stage-by-stage advice on assembly, deck details and rigging. 96 pages, 9½" × 7¼", illustrated, case bound.

£1.05 net, plus 13p p & p

### MAYFLOWER

No 2—Classic Ships series

By Noel C. L. Hackney

'Mayflower', second in the series, was published to coincide with the 350th anniversary of this famous ship's sailing. This indispensable book begins with an interesting account of the events that brought the Pilgrim Fathers together. The second part of the book is devoted to a highly detailed description of how to transform the Airfix kit into a model of exhibition quality. Will be enjoyed by all ship modellers. 80 pages, 9½" × 7¼", illustrated, case bound.

£1.05 net, plus 13p p & p

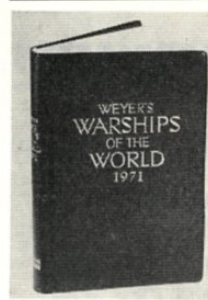

### WEYER'S WARSHIPS OF THE WORLD 1971

Compiled by Gerhard Albrecht

Now considered to be the most accurate manual in the English language on the fighting fleets of the world.

This United States Naval Institute book is a magnificent reference work for anyone interested in warship modelling. It lists detailed specifications of the world's warships and includes 362 photos and 1,237 drawings of the main classes of ships and naval aircraft. The 1971 edition of this highly regarded and well-established book contains up-to-date information on 97 of the world's navies.

£10.80 net, plus 20p p & p

## How to order

PSL books are published by Patrick Stephens Ltd, 9 Ely Place, London EC1N 6SQ (Tel: 01-405 2297). Use this order coupon to obtain your copies—post it to PSL or hand it to your bookseller or model shop. (Send for free descriptive leaflets if not convinced!) If you prefer not to cut your magazine, order on a piece of notepaper.

To: Patrick Stephens Ltd, 9 Ely Place, London EC1N 6SQ OR: YOUR BOOKSELLER OR MODEL SHOP

Please supply me with the following books: £

..... :  
 ..... :  
 ..... :  
 ..... :  
 I enclose my remittance of £..... (including postage and packing) TOTAL £

NAME .....  
 ADDRESS.....

(Block caps please) ..... (6/71)

## Four famous books for railway modellers



### 'TWIXT RAIL & SEA' and 'THE KING OF RAILWAY LOCOMOTIVES'

By W. G. Chapman

The next two books in the popular series of facsimile reprints from the GWR's 'Boys of All Ages' series. 'Twixt Rail & Sea' describes in detail the GWR's group of dockyards in South Wales, while 'The King' of Railway Locomotives examines the famous 'King' class locomotive. Originally published in the late 1920s, both books will make ideal reference sources for railway modellers. Published—June 7. £1.50 net each, plus 10p each p & p

## The first two titles

### THE 10.30 LIMITED and CAERPHILLY CASTLE

By W. G. Chapman

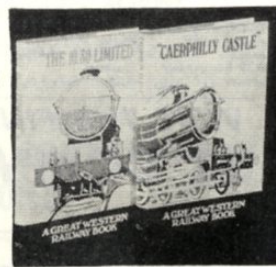

First two books in the series were welcomed with enthusiasm. 'The 10.30 Limited' concentrates on the workings of the GWR and contains an account of a journey made from London to Penzance on the 10.30 am Cornish Riviera Express, while 'Caerphilly Castle' covers many aspects of GWR steam locomotives and their history. Both books were originally published in the early 1920s.

£1.50 net each, plus 10p each p & p



### GUIDE TO THE SOVIET NAVY

By Siegfried Breyer

A US Naval Institute book

A guide to many aspects of the Soviet Navy, from the organisation of its hierarchy to details of its ship industry. Written by one of the Western world's leading authorities on the subject, it contains 266 superb illustrations. £4.75 net, plus 20p p & p

**AIRFIX** magazine

# Classified Adverts

RATES: 5p per word. Minimum charge 50p  
 BOX NUMBERS: 20p extra charge  
 All advertisements must be prepaid  
 Please state classification required

Please address your correspondence to:  
 AIRFIX MAGAZINE Classified Advertisement Department  
 9 Ely Place, London, EC1N 6SQ  
 Closing date for next issue—June 1

## FOR SALE

**German Warships** of the Second World War. A unique folio of authentic technical drawings featuring fifteen famous ships of the German Fleet, including Tirpitz, Kohn, Admiral Hipper, Gneisenau, Emden, Lutzow, Nurnberg, Admiral Scheer, Scharnhorst, Prinz Eugen, and others. These large drawings (size 17" × 10") are printed on high white cartridge paper and depict to scale a profile, plan, sections and end views of the ships. Armament and deck machinery is clearly shown. The folio is bound in stiff boards with a glaciae dust jacket at £1.50 plus 10p postage from Conway Maritime Press Ltd, 7 Nelson Road, Greenwich, London, SE10. All trade enquiries to trade distributors Patrick Stephens Limited, 9 Ely Place, London EC1. [970S]

**Broadside**, quarterly for Naval Wargamers, enthusiasts and 1200 collectors. 35p (7/-). A. C. James, 97a Kirkwood Road, London SE15. [971S]

**Airfix AFVs**, Conversions, Accessories, Soldiers. SAE lists, Moore, 57 Brunswick Road, London W5 1AQ. [972S]

**Lamming**, Wargame figures, Midlands agent. Also Historex agent. Painting done and animation to professional standards. Enclose SAE for lists, etc. Ward, 29 Tame Bank, Kingsbury, Tamworth, Staffs. [973S]

**Wargames Research Group** present infantry action rules 1925-1975, 48p post free. Also Ancient and 'Napoleonic' (1750-1850) 48p each. Medieval Adaptations to Ancient Rules 25p. 75 Ardingley Drive, Goring-by-Sea, Sussex. [974S]

**Old Model Kits**—Something new for the serious-minded modeller. The place to find that old kit you have been looking for. 'The Collectors Journal'. A newsletter dealing with ads to buy, sell, trade out of production model kits, books, pictures, etc. Distributed by subscription only, \$3.50 US, \$5.50 outside US (12 issues) plus \$1.00 for ad of 50 words or less. The Collectors Journal, 1225 Saxon Ave, Bay Shore, NY 11706, USA. [975S]

**New! Bare Metal Foil** model covering. Wafer thin foil conforms to all compound curves on aircraft, etc. This new American product is the last word in metal covering. Send 45p per sheet, post free, to the sole UK agent: D. S. Ives, 104 Longwood Gardens, Clayhall, Ilford, Essex. [978S]

**Reduced price kits**, aircraft, AFV, cars, miscellaneous. SAE for list. Box No 979S. [979S]

**WWII German Aircraft**, 35 made 1/72. £12 lot including kit instructions. Write E. Soumian, 12 Rhodes Avenue, London N22. [980S]

**Model Soldiers**, lead. 54 mm, perfect detail. Wide range, unpainted. Cowboys, Indians, farm and wild animals. 5p for list. 34 Beechfield Rd, Dublin 12. [981S]

**Swap!** Send any six secondhand paperback books (in good condition). Receive in exchange six different American Civil War posters. A.F. Swopshop, Irving Street, Dumfries, Scotland. [982S]

**Unmade kits**, Monogram B52, Mosquito, etc. UPC, Lindberg, large number, reduced prices. Box No 983S. [983S]

**Modakit** have reorganised and the following kits are available now. Aircraft 'Blister' Hangar. 50p each. P & P 10p. Conversion kit, three vehicles, Austin Fire Tender, Austin 30 cwt Truck, Airfield Controller's Caravan. 35p inclusive. P & P 5p. 'Nissen' Hut 35p each. P & P 5p. Please send SAE for list. Trade enquiries invited. 'Modakit', 13 Larchfield Way, Horndean, Hants PO8 9HE. [984S]

**Boeing 707**—1/72 scale models ready-made but with no undercarriage. Waiting to be painted in your own choice of colours. £4.98 plus 35p for postage and packing (UK only). Vacuum formed 1/72 scale kits: Islander, Sabreliner (45p), Hansa, Jetstar, Jetfalcon, Skyvan, Fouga-Magister, Dove, Fuji T1-F2 (55p), Gulfstream II, TSR2 (70p), H.S.748 (100p), Super Constellation (160p). PO with order plus 10p, overseas add 15p per £1 for surface mail. T.W.R. Models, 8 The Acre, Windsor, Berks. [985S]

**Airfix Magazines**, July 1967 to December 1970, offers, or would accept negatives of aircraft in exchange. Veitch, 15 Angle Park Terrace, Edinburgh EH11 2JX. [986S]

## WANTED

'Heller' Ship Kits, also large plastic coloured kit of liner 'France'. Box No 977W. [977W]

## MISCELLANEOUS

**Attention! Interesting demand from Germany.** We are the most important distributors in the mail-order section in our branch! For and around plastic modelling we are looking for suitable articles to be solely distributed by us in Germany. Interested parties manufacturing or dealing with those articles are requested to contact by airmail—simultaneously sending literature and samples of their products—Intermodel—Mr B. Engler, D-6551 Hargesheim, Germany. [976M]

**Interested in a Wargames Club** in Shoreham? Write 28 Ship Street, Shoreham-by-Sea, Sussex. [987M]

**FLYING LEATHERNECKS IN WORLD WAR II.** Aero Pictorial Vol. 4. 95 pages. 180 photos.

£1.90 post paid  
**DEBDEN EAGLES.** Story of 4th Fighter Group 8th Air Force W.W.II. 230 rare photos, 5 in full colour. 3 pages scale drawings. Complete list of aces. MAY. £3.40 post paid  
 W. E. Hersant Ltd., 228 Archway Road Highgate, London, N6 5AZ

Magnificent books for naval and maritime modellers and enthusiasts from the **UNITED STATES NAVAL INSTITUTE**

now readily available in Great Britain, British Commonwealth and Europe from the Sole Distributors

Patrick Stephens Limited  
 9 Ely Place, London EC1  
 (Tel 01-405 2297)

SEND FOR FULL CATALOGUE OF OVER 130 USNI BOOKS

THIS SPACE COSTS  
**JUST £13.50**

and will sell your product to readers of

**AIRFIX MAGAZINE**

For full details write or phone

**JACKSON-RUDD & ASSOCIATES LTD.**

Martin House,  
 84-86 Gray's Inn Road,  
 London, W.C.1  
 Tel: 01-405 3611

# to have and to hold... your AIRFIX magazines

The Classified Advertisement columns of this issue of AIRFIX MAGAZINE prove that copies of every issue become more and more valuable as time goes on. The circulation and readership increases steadily each month so that supply very often cannot keep up with the demand and you may well miss a copy. Make sure this doesn't happen to you by ordering a regular copy from your newsagent, or alternatively take out an annual subscription using the form below:

To: AIRFIX MAGAZINE — Subscription Dept.  
Surridge Dawson & Co. (Productions) Ltd.,  
136/142 New Kent Road, London, S.E.1.  
Please send my AIRFIX MAGAZINE each month by  
post on publication for a 12 month period commencing  
with the ..... issue. I enclose my cheque/  
postal order for £2.40. (Postage inclusive). (USA \$6.50)

Date..... Signed.....  
NAME.....  
ADDRESS.....

*Please write clearly in block capitals.* AM 6/71

Once you take AIRFIX MAGAZINE regularly, treat your copies like gold dust by preserving them in AIRFIX MAGAZINE EASIBINDERS. Order these now for your valuable back numbers, your last year's copies or even your next year's copies, using the form below.

To: AIRFIX MAGAZINE — Easibinder Dept.  
PSL Publications Ltd., 9 Ely Place, London, E.C.1.  
Please send me ..... special AIRFIX MAGAZINE  
Easibinder/s immediately at £1.25 each, post and  
packing free. I enclose my cheque/postal order  
for £..... Signed.....  
NAME.....  
ADDRESS.....

*Please write clearly in block capitals.* AM 6/71

## AIRFIX MRRRC

NEW FROM AIRFIX / MRRRC

### SUPER SOFT PICK-UP BRAIDS

fitted complete with QUICK RELEASE CLIPS to fit all popular makes of Slot Guides.

ECONOMY PACK OF 6

Cat. No. 1951

Price 20p

Please send 2p for catalogue and name of nearest stockist to:  
29 Ashley Road, Boscombe, Bournemouth, Hampshire.

NAME .....  
ADDRESS .....

## IAN ALLAN BOOKS

### AIR SCENE No. 2

Fascinating album of civil and military aviation photographs (in colour and black and white) compiled by Philip J. R. Moyes.

Including: Vickers Wellington I, Blackburn and Fairey naval aircraft (most of the famous old timers), the Hawker Hunter F1 (with emphasis on 43 Squadron—the Fighting Cocks), and Croydon Airport and its pre-war aeroplanes.

**Modellers, don't miss the Hunter and Wellington I pictured from every angle.**

Details: 11" x 8½", 48 pp. (4 in colour) 60p

Order direct or through leading booksellers:

**IAN ALLAN**

TERMINAL HOUSE  
SHEPPERTON, MIDDLESEX

## Get every detail right with Airfix



It's the little things—like the helicopters, operating stern ramp and Landing Craft—that really makes the model! And that's why Airfix Construction Kits are so fantastically popular. Every model is accurate to the smallest detail—a perfect replica of the real thing! There are nineteen different series, each made to a constant scale. Over 300 kits, at prices from 17p. At all good hobby shops and F. W. Woolworth. Ask for the catalogue.

Left: Suffolk. Bottom Right: Scharnhorst. Top Right: Ark Royal.

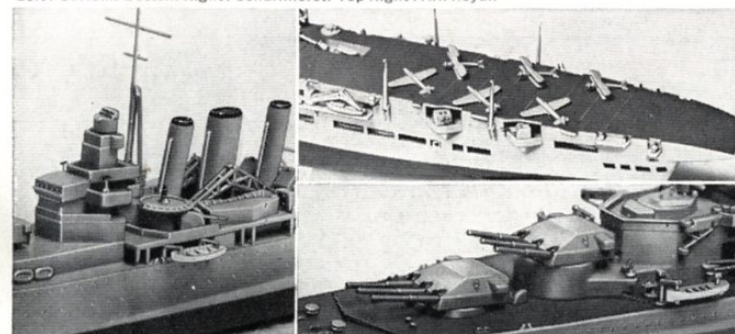

**PLANES!**  
Over 150 to choose from, including aircraft from both World Wars, modern jets and airliners.



**ARMoured VEHICLES!**  
Tanks, trucks and missiles, all in 'OO/HO' scale, for use with Airfix figures.



**STOP PRESS**



Powered by Rolls Royce RB211 jet engines and designed to operate over short and medium distances, the wide bodied TriStar is capable of carrying up to 345 passengers. This superb Airfix Kit is supplied with Air Canada markings. 85p.

News, articles, conversions for modelling enthusiasts every month in AIRFIX MAGAZINE. 15p from your model shop or newsagent.



The world's  
biggest range of  
construction kits



# YOUR INTERNATIONAL MODEL MAIL ORDER HOUSE



Suppliers to the British and Overseas Governments

## ★ ★ ★ ★ AIRCAM AVIATION SERIES ★ ★ ★ ★

- |   |       |  |            |
|---|-------|--|------------|
| No. 1 NORTH AMERICAN P-40 WARHAWK       | £1.05 | No. 14 REPUBLIC F/RF-84F THUNDERSTREAK/THUNDERFLASH  | £1.05      |
| No. 2 REPUBLIC P-47 THUNDERBOLT         | £1.05 | No. 15 BOEING B-17B-H FLYING FORTRESS  | £1.05      |
| No. 3 NORTH AMERICAN MUSTANG Mk. I-IV   | £1.05 | No. 17 NORTH AMERICAN F-86A-L SABRE  | £1.05      |
| No. 4 SUPERMARINE SPITFIRE Mk. I-XVI    | £1.05 | No. 18 NAKAJIMA Ki 27A-B   | £1.05      |
| No. 5 NORTH AMERICAN P-51B/C MUSTANG    | £1.05 | No. 19 HELLCAT   | £1.05      |
| No. 6 CURTISS (P-40) KITTYHAWK Mk. I-IV | £1.05 | S.1 BATTLE OF BRITAIN  | £1.05      |
| No. 7 CURTISS P-40 WARHAWK              | £1.05 | S.2 FINNISH AIR FORCE  | £1.05      |
| No. 8 SUPERMARINE SPITFIRE Mk. XII-24   | £1.05 | SHARKMOUTH—In two volumes  | each £1.05 |
| No. 9 SPAD SCOUTS S.VII and S.XIII      | £1.05 | S.3 Volume I. S.4 Volume II.   |            |
| No. 10 LOCKHEED P-38 LIGHTNING          | £1.05 | "NEW" No. S6 Volume 1 LUFTWAFFE COLOUR SCHEMES AND MARKINGS 1935-45. This book covers Fighters and Ground Attack types | £1.05      |
| No. 11 CONSOLIDATED B-24-M LIBERATOR    | £1.05 | 2nd TACTICAL AIR FORCE By Christopher F. Sheres  | £4.00      |
| No. 12 AVRO LANCASTER                   | £1.05 |  |            |
| No. 13 NAKAJIMA Ki 43                   | £1.05 |  |            |



## Exciting world of BOOKS



**ALMARK PUBLICATIONS**  
**'Battle' Class Destroyers** by Peter Hodges  
 This is a monograph devoted to the famous Royal Navy Battle Class ships. Every ship is illustrated, there is a detailed historical and technical coverage including cutaways of weapons systems. 5-colour plates.  
 Paperback Edition £1.25  
 Bound with dustjacket £1.75

**Ships of the Royal Navy** by W. D. G. Blundell  
 This book shows all current R.N. ships with both scale drawings and large pictures and with every class or ship illustrated. Some ships yet to enter service, are also shown.  
 Paperback Edition £1.25  
 Bound with dustjacket £1.75

**OTHER PUBLICATIONS**  
 German Weapons, Uniforms, Insignia 1841-1918 £2.70  
 Handbook of German Army identification 1943 £1.80  
 Foreign Volunteers of Hitler's Germany £1.80  
 German Military Uniforms and Insignia 1933-1945 £3.75  
 German Army, Navy Uniforms, insignia of World War One £4.00  
 Edged Weapons £4.20  
 Antique Firearms £4.20  
 Military Field Works 18th and 19th Century 25p  
 Military Field Works 20th Century 40p  
 Firearms in England in the 14th Century £1.50

The Focke-Wulf 190 £3.50  
 The Messerschmitt 109 £3.50  
 Lancaster £3.50  
 Fighter Aircraft of the 1914-18 War £3.50  
 The Aces of the 1914-18 War £3.50  
 Fokker—The Man and the Aircraft £3.50  
 Aircraft Camouflage and Markings 1907-1954 £4.00  
 Aircraft Markings of the World 1912-1967 £4.00

**Aero A.F.V. Publications**  
 Vol. 1 The Tiger Tanks  
**Aero A.F.V. Publications with colour art**  
 Vol. 1 The Tiger Tanks £1.18  
 Vol. 2 The German Panzers £1.18  
 Vol. 3 Sturmartillerie £1.18  
 Vol. 4 Sturmartillerie Part II £1.18  
 Vol. 5 Strassenpanzer £1.18  
 Vol. 6 Armour on the Eastern Front £1.18  
 Vol. 7 Halbkettenfahrzeuge £1.18  
 Vol. 8 Armour in the Western Front £1.18  
 Vol. 9 Sonderpanzer £1.18  
 Vol. 10 Militarfahrzeuge £1.18

## MONOGRAM AIRCRAFT AND A.F.V. KITS

- |                      |      |     |                  |      |     |                     |       |
|----------------------|------|-----|------------------|------|-----|---------------------|-------|
| Messerschmitt Bf-110 | 1/72 | 60p | Stuka Ju-87G1    | 1/48 | 90p | GERMAN PANZER IV    | £1.50 |
| Tigercat F7F-3       | 1/72 | 60p | Hawker Typhoon   | 1/48 | 90p | GERMAN FLAK PANZER  | £1.50 |
| Dornier DO-17        | 1/72 | 90p | Mustang P-51B    | 1/48 | 60p | GERMAN ASSAULT TANK | £1.50 |
| Mustang P51B         | 1/72 | 45p | Skyraider A-1E   | 1/48 | 60p |                     |       |
| Airacobra P-39       | 1/48 | 90p | Dauntless SBD    | 1/48 | 90p |                     |       |
| Messerschmitt Me-109 | 1/48 | 60p | Avenger TBF      | 1/48 | 90p |                     |       |
| Spitfire             | 1/48 | 60p | Helldiver SB2C-5 | 1/48 | 90p |                     |       |
| Hawker Hurricane     | 1/48 | 60p | Hellcat F6F      | 1/48 | 90p |                     |       |
| Focke-Wulf Fw-190    | 1/48 | 60p | Corsair F4U-4    | 1/48 | 90p |                     |       |
| Huey Armed Chopper   | 1/48 | 60p | Thunderbolt P-47 | 1/48 | 90p |                     |       |
| Huey Rescue Chopper  | 1/48 | 60p |                  |      |     |                     |       |

## TAMIYA A.F.V. KITS

1/35 SCALE



3 TAMIYA A.F.V. KITS 1/35 Scale  
 Kfz 1/20 K2S SCHWIMMWAGEN German Amphibious Volkswagen jeep 65p  
 PKwK1 (Type 82) KUBELWAGEN  
 German Volkswagen  
 British Army POUNDER ANTI-TANK GUN 65p

## ALMARK KITS

54 mm PLASTIC FIGURES F.3. New U.S. Army Infantry 1943-45

- \* THIRTEEN different figures including seated driver or passenger.
- \* Weapons include M1 rifle or SMG, Browning Automatic Rifle, and bazooka.
- \* Choice of helmets or forage caps.
- \* Complete with painting instructions.

ALSO 75p per set  
 F.1. Panzer-Grenadiers  
 F.2. Japanese Infantry  
 The figures with unlimited conversion possibilities.



NOW IN STOCK

FIGURES by the following: GARRISON, OLIVE, LASSET, HISTOREX, STADDEN, HINTON HUNT, ROSE, MINIATURE FIGURINES

SEE ALSO OUR ADVERT ON PAGE 545

Post and Packing: Please add 10% to all orders up to £5.00. (min. 10p) Over £5.00 post free. C.O.D. Charge 45p